



Test Report issued under the responsibility of:



TEST REPORT IEC 60884-1 Plugs and socket-outlets for household and similar purposes Part 1: General requirements	
Report Number.:	T211-0028/26
Date of issue	2026-01-15
Total number of pages	142
Name of Testing Laboratory preparing the Report.....:	SIQ Ljubljana SIQ Ljubljana is accredited by Slovenian Accreditation with accreditation number LP-009 in the field of testing (SIST EN ISO/IEC 17025).
Applicant's name.....:	ALING – CONEL d.o.o.
Address	Železnička 10, 21432 Gajdobra, Serbia
Test specification:	
Standard	IEC 60884-1:2022
Test procedure	CB Scheme
Non-standard test method.....:	N/A
TRF template used	IECEE OD-2020-F1:2023, Ed.1.6
Test Report Form No.....:	IEC60884_1K
Test Report Form(s) Originator	IMQ S.p.A.
Master TRF	Dated 2024-04-18
Copyright © 2024 IEC System of Conformity Assessment Schemes for Electrotechnical Equipment and Components (IECEE System). All rights reserved. This publication may be reproduced in whole or in part for non-commercial purposes as long as the IECEE is acknowledged as copyright owner and source of the material. IECEE takes no responsibility for and will not assume liability for damages resulting from the reader's interpretation of the reproduced material due to its placement and context. If this Test Report Form is used by non-IECEE members, the IECEE/IEC logo and the reference to the CB Scheme procedure shall be removed. This report is not valid as a CB Test Report unless signed by an approved IECEE Testing Laboratory and appended to a CB Test Certificate issued by an NCB in accordance with IECEE 02.	
General disclaimer:	
The test results presented in this report relate only to the object tested. This report shall not be reproduced, except in full, without the written approval of the Issuing NCB. The authenticity of this Test Report and its contents can be verified by contacting the NCB, responsible for this Test Report.	

Test item description :	Flush mounted Socket-outlet	
Trademark(s)	ALING - CONEL	
Manufacturer	ALING – CONEL d.o.o., Železnička 10, 21432 Gajdobra, Serbia	
Model/Type reference :	art.604.xx	
Ratings :	16 A; 250 V~	
Responsible Testing Laboratory (as applicable), testing procedure and testing location(s):		
<input checked="" type="checkbox"/>	CB Testing Laboratory:	SIQ Ljubljana
Testing location/ address	Mašera-Spasičeva ulica 10, SI-1000 Ljubljana, Slovenia	
Tested by (name, function, signature) :	Nejc Krajnik (Authorisation of test report) Service provider	
Approved by (name, function, signature) .. :	Tibor Kokelj Reviewer	
<input type="checkbox"/>	Testing procedure: CTF Stage 1:	
Testing location/ address		
Tested by (name, function, signature) :		
Approved by (name, function, signature) .. :		
<input type="checkbox"/>	Testing procedure: CTF Stage 2:	
Testing location/ address		
Tested by (name + signature) :		
Witnessed by (name, function, signature) . :		
Approved by (name, function, signature) .. :		
<input type="checkbox"/>	Testing procedure: CTF Stage 3:	
<input type="checkbox"/>	Testing procedure: CTF Stage 4:	
Testing location/ address		
Tested by (name, function, signature) :		
Witnessed by (name, function, signature) . :		
Approved by (name, function, signature) .. :		
Supervised by (name, function, signature) :		

<p>List of Attachments (including a total number of pages in each attachment):</p> <ul style="list-style-type: none"> - Attachment No.1: Dimensions (2 pages) - Attachment No.2: Photos (3 pages) - Attachment No.3: Technical documentation (3 pages) 	
<p>Summary of testing:</p>	
<p>Tests performed (name of test, test clause and date test performed):</p> <p>All applicable test have been performed</p>	<p>Testing location: (CBTL, SPTL, CTF, Subcontractor)</p> <p>SIQ Ljubljana Tržaška cesta 2, SI-1000 Ljubljana, Slovenia</p> <p>SIQ Ljubljana Mašera-Spasičeva ulica 10, SI-1000 Ljubljana, Slovenia</p>
<p>Summary of compliance with National Differences</p> <p><i>Include only National Differences evaluated and declared by member countries of IECEE CB Scheme. Non-member countries or national or regional standards can be included for information in the General Product Information section of the Test Report but will not to be listed on CB Test Certificate. (See OD 2037, item 7.1).</i></p> <ul style="list-style-type: none"> • IECEE Member countries that are also CENELEC members <p style="padding-left: 40px;">Compliance with Group Differences evaluated <input type="checkbox"/> yes <input type="checkbox"/> No <input checked="" type="checkbox"/> N/A</p> <ul style="list-style-type: none"> • IECEE Member countries with published National Differences which were evaluated: N/A • IECEE Member countries that did not publish any National Differences: N/A <p style="padding-left: 40px;">To support compliance with published National Differences, attach a compilation of relevant ND and/or GD TRFs to the CB Test Report</p> <p><input checked="" type="checkbox"/> The product fulfils the requirements of IEC 60884-1:2022</p>	

Use of uncertainty of measurement for decisions on conformity (decision rule) :

No decision rule is specified by the IEC standard, when comparing the measurement result with the applicable limit according to the specification in that standard. The decisions on conformity are made without applying the measurement uncertainty ("simple acceptance" decision rule, previously known as "accuracy method").

Other: ... (to be specified, for example when required by the standard or client, or if national accreditation requirements apply)

Information on uncertainty of measurement:

The uncertainties of measurement are calculated by the laboratory based on application of criteria given by OD-5014 for test equipment and application of test methods, decision sheets and operational procedures of IECEE.

IEC Guide 115 provides guidance on the application of measurement uncertainty principles and applying the decision rule when reporting test results within IECEE scheme, noting that the reporting of the measurement uncertainty for measurements is not necessary unless required by the test standard or customer.

Calculations leading to the reported values are on file with the NCB and testing laboratory that conducted the testing.

Copy of marking plate (examples):

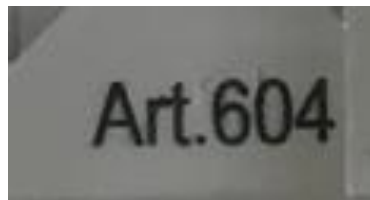

The artwork below may be only a draft. The use of certification marks on a product must be authorized by the respective NCBs that own these marks.



Test item particulars :	
Classification of installation and use :	Socket-outlet intended for flush mounting
Supply Connection :	Terminals
Standard Sheet: CEE 7 (S.S. III)	
Rated current (A) / Rated voltage (V): 16 A; 250 V~	
Degree of protection against access to hazardous parts and against harmful ingress of solid foreign objects: <input checked="" type="checkbox"/> IP2X <input type="checkbox"/> IP4X <input type="checkbox"/> IP5X	
Degree of protection against harmful ingress of water: <input checked="" type="checkbox"/> IPX0 <input type="checkbox"/> IPX4 <input type="checkbox"/> IPX5 <input type="checkbox"/> IPX6	
Provision for earthing: <input type="checkbox"/> without earthing contact	
Method of connecting the cable: <input checked="" type="checkbox"/> rewirable <input type="checkbox"/> non-rewirable	
Type of cable: /	
Nominal cross-sectional areas (mm²): /	
Type of terminals: <input checked="" type="checkbox"/> screw-type <input type="checkbox"/> screwless-type (rigid) <input type="checkbox"/> screwless-type (rigid and flexible) <input type="checkbox"/> insulation piercing terminals (IPT)	
Type of connections: <input type="checkbox"/> soldered <input type="checkbox"/> welded <input type="checkbox"/> crimped <input type="checkbox"/> other	
Socket-outlets:	
Degree of protection against electric shock: <input checked="" type="checkbox"/> normal protection <input type="checkbox"/> increased protection	
Existence of shutters: <input checked="" type="checkbox"/> without shutters <input type="checkbox"/> with shutters	
Method of application / mounting of the socket-outlet: <input type="checkbox"/> surface-type <input checked="" type="checkbox"/> flush-type <input type="checkbox"/> semi-flush-type <input type="checkbox"/> panel type <input type="checkbox"/> architrave-type <input type="checkbox"/> portable type <input type="checkbox"/> table-type (single/multiple) <input type="checkbox"/> floor recessed type <input type="checkbox"/> appliance type	
Method of installation: <input checked="" type="checkbox"/> design A <input type="checkbox"/> design B	
Intended for circuits where: <input checked="" type="checkbox"/> a single earthing circuit provides protective earthing <input type="checkbox"/> electrical noise immunity is desired for the earthing circuit	
Plugs:	
Class of equipment: <input type="checkbox"/> 0 <input type="checkbox"/> I <input type="checkbox"/> II	
Possible test case verdicts:	
- test case does not apply to the test object.....: N/A	
- test object does meet the requirement.....: P (Pass)	
- test object does not meet the requirement.....: F (Fail)	
Testing :	
Date of receipt of test item: 2012-07-03; 2025-07-23	
Date (s) of performance of tests: (2013-01-02) – (2013-02-07); 2017-07-17; (2025-07-24) – (2026-01-15)	

General remarks:			
"(See Enclosure #)" refers to additional information appended to the report. "(See appended Table)" refers to a Table appended to the report.			
Throughout this report a <input checked="" type="checkbox"/> comma / <input type="checkbox"/> point is used as the decimal separator.			
Manufacturer's Declaration per sub-clause 4.2.5 of IEC 60335-1:			
The application for obtaining a CB Test Certificate includes more than one factory location and a declaration from the Manufacturer stating that the sample(s) submitted for evaluation is (are) representative of the products from each factory has been provided :	<input checked="" type="checkbox"/> Yes <input type="checkbox"/> Not applicable		
When differences exist; they shall be identified in the General product information section.			
Name and address of factory (ies)	ALING – CONEL d.o.o., Železnička 10, 21432 Gajdobra, Serbia		
General product information and other remarks:			
Flush mounted socket-outlet for mounting into installation box Ø 60 mm is part of PRESTIGE family of products Socket-outlets are provided with claws for mounting.			
Art.604.xx where (.xx) is color code mark: (examples of color codes) <ul style="list-style-type: none"> 00 – white 01 – white with grey interframe 20 – graphite with white interframe 21 – graphite with grey interframe 30 – dark red with white interframe 32 – dark red with graphite interframe 99 – beige S2 – silver with graphite interframe E1E1 – soft black 			
With cover parts: art.604.05 for art.604.00 (white), art.604.99 (beige), art.604.E1E1 (soft black) art.604.01 for art.604.xx (other colors)			
History sheet			
Report No.	Date	Change	Revision No.
T211-0102/13	2013-03-04	Initial Test Report issued.	--
T211-0554/17	2017-07-18	Test report updated to the newest TRF version including A2.	1.0
T211-0554/17 M1	2022-05-18	Test report updated due to new colours added in general product information.	1.1

T211-0028/26	2026-01-15	Test report updated to the latest standard edition and test report form. Dimensions remeasured.	2.0
--------------	------------	-------------------------------------------------------------------------------------------------	-----

IEC 60884-1			
Clause	Requirement + Test	Result - Remark	Verdict
8	MARKING		P
8.1	General		P
	Accessories marked as follows		P
	- rated current (A)	16 A	P
	- rated voltage (V)	250 V	P
	- symbol for nature of supply	~	P
	- name, trademark or identification mark of manufacturer's or responsible vendor's name	ALING-CONEL logo	P
	- type reference	art.604.xx	P
	- degree of protection (first characteristic numeral) if higher than 2	IP20	N/A
	- degree of protection (second characteristic numeral) if higher than 0	IP20	N/A
	- degree of protection (first characteristic numeral) higher than 4 for fixed socket outlet in which case the second characteristic numeral shall also be marked		N/A
	- degree of protection (second characteristic numeral) higher than 2 for fixed socket outlet in which case the first characteristic numeral shall also be marked		N/A
	Socket-outlets with screwless-type terminals marked with the following:		N/A
	- the length of insulation to be removed		N/A
	- an indication of the suitability to accept rigid conductors only (if any)		N/A
8.2	Symbols used		P
	Symbols used as follows		P
	Amperes: A		P
	Volts: V		P
	Alternating current: ~ or AC		P
	Neutral: N		N/A
	Protective earth: 		P
	Degree of protection: IPXX		N/A
	Degree of protection for fixed accessories also able to be installed on rough surfaces 		N/A
	Screwless-type terminals: suitability to accept rigid conductors only: r		N/A

IEC 60884-1			
Clause	Requirement + Test	Result - Remark	Verdict
	Rated current and rated voltage values may be used alone (oblique or horizontal line)		N/A
	Marking for the nature of supply placed next to the marking for rated current and rated voltage		P
8.3	Particular requirements for fixed socket-outlets		P
	Marking placed on the main part		P
	- rated current, rated voltage and nature of supply		P
	- identification mark of the manufacturer or of the responsible vendor		P
	- length of insulation to be removed, if any		N/A
	- indication of the suitability to accept rigid conductors only for screwless-type terminals for those socket-outlets having this restriction	r	N/A
	- type reference		P
	Cover plates necessary for safety purposes and intended to be sold separately: marked with the manufacturer's or responsible vendor's name, trademark or identification mark and type reference		N/A
	IP code, if applicable: marked so as to be easily discernible		N/A
	Fixed socket-outlets classified according to 7.2.5.2: identified by a triangle visible after installation unless they have an interface configuration different from that used in normal circuits		N/A
8.4	Particular requirements for portable accessories		N/A
	Plugs and portable socket-outlets: marking specified in 8.1, other than the type reference, easily discernible		N/A
	Plugs and portable socket-outlets for equipment of class II not marked with the symbol for class II construction		N/A
8.5	Particular requirements for markings on terminals other than phase terminals		P
	Neutral terminals indicated by the letter N		N/A
	Earthing terminals indicated by the symbol 		P
	Markings not placed on screws or other easily removable parts		P
	Terminals for conductors not forming part of the main function of the socket-outlet:		N/A
	- clearly identified unless their purpose is self-evident, or		N/A

IEC 60884-1			
Clause	Requirement + Test	Result - Remark	Verdict
	- indicated in a wiring diagram fixed to the accessory		N/A
	Identification of such terminals may be achieved by:		N/A
	- their being marked with graphical symbols according to IEC 60417 or colours and/or alphanumeric system, or		N/A
	- their being marked with their physical dimensions or relative location		N/A
8.6	IP code marking for surface-type mounting boxes forming an integral part of socket-outlets		N/A
	Surface-type mounting boxes forming an integral part of socket-outlets having an IP code higher than IP4X, or higher than IPX2, the IP code marked on the outside of its associated enclosure so as to be easily discernible		N/A
8.7	Additional requirement for marking		N/A
	Indication of which position or with which special provisions the declared degree of protection of fixed socket-outlets having an IP code higher than IPX0 is ensured		N/A
8.8	Durability		P
	Marking easily legible, durable and indelible		P
	Inspection using normal or corrected vision, without additional magnification	Laser engraved, moulded	P
	Test, if necessary, is done by:		N/A
	- rubbing the mark for 15 s with cotton cloth soaked with water - rubbing the mark for 15 s with cotton cloth soaked with n-hexane 95 %		N/A
	Rubbing started immediately after soaking the piece of cotton		N/A
	Compression force of (5 ± 1) N applied at a rate of approximately one cycle per second		N/A
	Compression force applied by means of a test piston having the dimensions specified in Figure 5		N/A
	Test piston made of an elastic material inert to test liquids and having a Shore-A hardness of 47 ± 5		N/A
9	CHECKING OF DIMENSIONS		P
9.1	General	See Attachment No.:1 CEE 7, Standard sheet III, (2P + E);	P

IEC 60884-1			
Clause	Requirement + Test	Result - Remark	Verdict
	Accessories and surface-type mounting boxes comply with the appropriate standard sheets and corresponding gauges, if any	See Annex	N/A
	Insertion of plugs into fixed or portable socket-outlets ensured by their compliance with the relevant standard sheets		P
	Compliance checked by ten insertions / withdrawals of a plug, having maximum dimension checked by measurement and / or by means of gauges, with manufacturing tolerances as shown in Table 3	See Attachment No.1	P
	Test as described in 22.4 carried out on the same samples after the ten insertions / withdrawals have been performed		P
9.2	Dangerous compatibility		P
	It is not possible to engage a plug with:		P
	- a socket-outlet having a higher voltage rating or a lower current rating;		P
	- a socket-outlet with a different number of live poles (exception admitted provided that no dangerous situation can arise);		P
	- a socket-outlet with earthing contact, if the existing plug of the present national system is a plug for class 0 equipment;		N/A
	Engagement of an existing plugs on the relevant national system for equipment of class 0 or of class I with a socket-outlet exclusively designed to accept plugs for class II equipment		N/A
	Impossibility of insertion checked by applying the gauge, for 1 min, with a force of:		P
	- 150 N (rated current \leq 16A);		P
	- 250 N (rated current $>$ 16A)		N/A
	Accessories with elastomeric or thermoplastic material: test carried out at (35 ± 2) °C		P
9.3	Permitted deviations		N/A
	Deviations from standard sheets made only if they provide technical advantage and do not affect the purpose and safety of accessories complying with standard sheet, with regard to interchangeability and non-interchangeability		N/A
10	PROTECTION AGAINST ELECTRIC SHOCK		P
10.1	General		P

IEC 60884-1			
Clause	Requirement + Test	Result - Remark	Verdict
	Accessories shall ensure protection against electric shock		P
10.2	Accessibility of live parts during normal use		P
	Plugs when engaged, fixed and portable socket-outlets designed and constructed that when they are mounted and or wired as for normal use, live parts are not accessible, even after removal of parts which can be removed without the use of a tool		P
	Live parts of plugs no accessible when it is in partial or complete engagement		P
	Compliance checked by test:		P
	- specimen mounted as for normal use		P
	- fitted with conductors smallest nominal cross-sectional area		P
	- then with conductors largest nominal cross-sectional area		P
	Table 4 screw-type terminals		P
	Table 8 screwless-type terminals		N/A
	Test probe B of IEC 61032 applied in every position		P
	Plugs are partially and complete engaged in socket-outlets		P
	Accessories with elastomeric or thermoplastic material: additional test carried out at $(35 \pm 2) ^\circ\text{C}$ with test probe 11 of IEC 61032 (75 N for 1 min)		P
	During the test: accessories do not deform, and live parts does not accessible		P
	Plugs and portable socket-outlets pressed with a force of 150 N for 5 min as shown in Figure 6: specimens do not show deformation		P
10.3	Requirements for accessible parts of accessory during normal use		P
10.3.1	Accessible parts made of insulating materials, with exception for:		P
	- small screws and the like, isolated from live parts, used for fixing main parts, covers, cover plates or other parts		P
	- covers, cover plates, other parts of fixed socket-outlets and accessible parts of portable socket-outlets and plugs of metal, comply with 10.3.2 or 10.3.3		N/A
	- earthing pins, earthing straps		P

IEC 60884-1			
Clause	Requirement + Test	Result - Remark	Verdict
	- current carrying pins and metal shoulders around pins of plugs		N/A
10.3.2	Cover, cover plates, other parts of metal protected by additional insulation made by insulating linings or insulating barriers. They are either:		P
	- be fixed in such a way that they cannot be removed without being permanently damaged, or		P
	- be so designed that: <ul style="list-style-type: none"> cannot be replaced in an incorrect position 		P
	<ul style="list-style-type: none"> if omitted the accessories are inoperable or incomplete 		P
	<ul style="list-style-type: none"> no risk of accidental contact between live parts and metal covers, cover plates, other parts, e.g., fixing screws, even if a conductor should come away from its terminal 		P
	<ul style="list-style-type: none"> creepage, clearance distances becoming less than values of Table 26 		P
	<ul style="list-style-type: none"> comply with Clauses 17 and 27 		P
10.3.3	Earthing of metal cover or cover plates made with fixing screws or other integral means: connection of low resistance		N/A
	Creepage and clearance distances between live pins of a plug when fully inserted and the earthed metal cover of a socket-outlet comply with item 2 and 7 of Table 26		N/A
10.4	Single-pole insertion		P
	Contact between a pin of a plug and a live socket-contact of a socket-outlet not possible while any other pin is accessible		P
	Compliance checked by manual test and by means of gauges (most unfavourable dimensions). Tolerances as specified in Table 3		P
	Accessories with elastomeric or thermoplastic material: test carried out at $(35 \pm 2) ^\circ\text{C}$		P
	Socket-outlets with enclosure or bodies of rubber or polyvinyl chloride: test carried out with a force of 75 N for 1 min		N/A
	Fixed socket-outlets provided with metal covers or cover plates: clearance of at least 2 mm required between a pin and a socket-contact when another pin(s) is(are) in contact with the metal covers or cover plates (mm).....:		N/A

IEC 60884-1			
Clause	Requirement + Test	Result - Remark	Verdict
	Single-pole insertion prevented by the use at least:		P
	- a large cover or cover plate		P
	- other means (e.g., shutters)		N/A
10.5	Shuttered socket-outlets		N/A
	Constructed that live parts not accessible, without a plug in engagement, with the gauges shown in Figures 7 and 8		N/A
	They do not touch live parts when applied to the entry holes corresponding to the live contact.		N/A
	Live contacts automatically screened when the plug is withdrawn		N/A
	Shutters so designed that a plug is inserted with the same movement in a socket-outlet with shutters as in a socket-outlet without shutters		N/A
	Means cannot easily be operated by anything other than a plug and not depend upon parts which are liable to be lost		N/A
	Gauge of Figure 7		N/A
	- applied to the entry holes corresponding to live contacts with a force of 20 N		N/A
	- most unfavourable position		N/A
	- successively in three directions, to the same place		N/A
	- for approximately 5 s in each of three directions		N/A
	- it does not be rotated		N/A
	- it is applied in such a way that the 20 N force is maintained.		N/A
	- moving the gauge from one direction to the next, no force is applied but the gauge is not withdrawn		N/A
	Gauge of Figure 8, applied with a force of 1 N		N/A
	- in three directions, for 5 s in each direction		N/A
	- independent movements		N/A
	- withdrawing the gauge after each movement		N/A
	Accessories with elastomeric or thermoplastic material: test carried out at $(35 \pm 2) ^\circ\text{C}$		N/A
10.6	Deformation of earthing contacts		P
	Earthing contacts of a socket-outlet designed that they cannot be deformed by the insertion of a plug		P

IEC 60884-1			
Clause	Requirement + Test	Result - Remark	Verdict
	Test plug inserted into the socket-outlet with a force of 150 N for 1 min		P
	After this test: socket-outlet still comply with the requirements of clause 9		P
10.7	Socket-outlet with increased protection		N/A
	- with or without lid		N/A
	- according to 7.2.1.2		N/A
	- mounted and wired for normal use		N/A
	Test wire of 1 mm diameter (Figure 8) applied with a force of 1 N		N/A
	- on all accessible surfaces		N/A
	- most unfavourable conditions		N/A
	- without a plug inserted		N/A
	- with the lid, if any, open		N/A
	Accessories with elastomeric or thermoplastic material: test carried out at $(35 \pm 2) ^\circ\text{C}$		N/A
	- live parts not accessible		N/A
11	PROVISION FOR EARTHING		P
11.1	General		P
	Earth connection made before the current-carrying contacts of the plug become live		P
	Current-carrying pins are separated before the earth connection is broken		P
11.2	Earthing terminals		P
	- of rewirable accessories:		P
	<ul style="list-style-type: none"> • comply with clause 12 		P
	<ul style="list-style-type: none"> • the same size as the corresponding terminals for the supply conductors 	Allow the connection of two 2,5 mm ² conductors	P
	<ul style="list-style-type: none"> • internal 		P
	- of fixed socket-outlet:		P
	<ul style="list-style-type: none"> • can have additional external earthing terminal 		N/A
	<ul style="list-style-type: none"> • fixed to the base or to a part reliably fixed to the base 		P
	<ul style="list-style-type: none"> • fixed to the base, or 		P
	<ul style="list-style-type: none"> • fixed to the cover, automatically and reliably connected to the earthing terminal when the cover is put in place 		N/A

IEC 60884-1			
Clause	Requirement + Test	Result - Remark	Verdict
	<ul style="list-style-type: none"> contact pieces silver plated or 		N/A
	<ul style="list-style-type: none"> protected against corrosion and abrasion 		P
	Connection ensured under all conditions		P
	Parts of earthing circuit in one piece or reliably connected by riveting, welding, or the like		P
11.3	Accessible metal parts		P
	of accessories: permanently and reliably connected to the earthing terminal	Earthing strips	P
11.4	Socket-outlets, having an IP code higher than IPX0		N/A
	with enclosure of insulating material and more than one cable inlet, provided with:		N/A
	<ul style="list-style-type: none"> an internal fixed earthing terminal, or 		N/A
	<ul style="list-style-type: none"> adequate space for a floating terminal (test connection using the type of terminal specified by the manufacturer), unless 		N/A
	<ul style="list-style-type: none"> earthing terminal of socket-outlet itself allows the connection of an incoming and an outgoing earthing conductor 		N/A
11.5	Internal connection with the earthing terminal		P
	and accessible metal parts: of low resistance		P
	Test current equal to 1,5 times the rated current or 25 A (A)	25 A	—
	Resistance does not exceed 0,05 Ω (Ω)	0,01 Ω	P
11.6	Fixed socket-outlets according to 7.2.5.2		N/A
	- earthing socket contact and its terminal electrically separated from any metal mounting means or		N/A
	- other exposed conductive parts which may be connected to the protective earthing circuit of the installation		N/A
12	TERMINALS AND TERMINATIONS		P
12.1	General		P
	All the test on terminals, with the exception of the tests of 12.3.11 and 12.3.12, made after the test of clause 16		P
12.1.1	Rewirable accessories provided with clamping-screw terminals or with screwless-type terminals ...	Screw-type terminals	P
	Pre-soldered flexible conductors used: pre-soldered area outside the clamp area of screw-type terminals		N/A

IEC 60884-1			
Clause	Requirement + Test	Result - Remark	Verdict
	Clamping means of terminals: not serve to fix any other components		P
	Non-rewirable accessories provided with soldered, welded, crimped or equally effective permanent connections (termination)		N/A
	Screwed or Snap-On connections not used		N/A
	Connections made by crimping a pre-soldered flexible conductor not permitted		N/A
12.2	Terminals with screw clamping for external copper conductors		P
12.2.1	Screw clamping terminals suitable:		P
	• rigid copper conductors only		P
	• both rigid and flexible copper conductors		N/A
	Screw clamping terminals for rewirable portable accessories suitable for flexible copper conductors		N/A
	Cross-sectional area as shown in Table 4	From 1,5 mm ² up to 2 x 2,5 mm ²	—
	Diameter of the largest conductor (mm).....:	2,13 mm	—
	Figure of terminal.....:	<input checked="" type="checkbox"/> 9 <input checked="" type="checkbox"/> 10 <input type="checkbox"/> 11 <input type="checkbox"/> 12	—
	Minimum diameter D (minimum dimensions) of conductor space: required (mm); measured (mm)....:	(E) Fig. 9: 3,0 mm / 3,8 (L/N) Fig. 10: 2,0 mm / 2,7 mm	—
	Minimum distance g between clamping screw / end of conductor fully inserted	Fig. 9: 1,5 mm / 3,1 mm	—
	Torque (Nm).....:	Fig. 9: 0,8 Nm Fig. 10: 0,8 Nm	—
12.2.2	Terminals allow the conductor to be connected without special preparation		P
12.2.3	Terminals have adequate mechanical strength		P
	Screws and nut for clamping the conductors have metric ISO thread or a comparable thread		P
	Screws not of soft metal such as zinc or aluminium		P
12.2.4	Terminals resistant to corrosion		P
12.2.5	Terminals clamp the conductor(s) without undue damage (test apparatus according to Figure 13)	See appended table 12.2.5	P
	During the test: conductor do not slip out, no break near clamping unit and no damage		P
12.2.6	Terminals clamp the conductor reliably between metal surfaces	See appended table 12.2.6	P

IEC 60884-1			
Clause	Requirement + Test	Result - Remark	Verdict
	During the test: conductor do not move noticeably		P
12.2.7	Terminals designed or placed that the conductor cannot slip out while the clamping screws or nuts are tightened	See appended table 12.2.7	P
	After the test: no wire of the conductor escaped from the clamping unit		P
12.2.8	Terminals do not work loose from their fixing to accessories		P
	Torque test (screws and nuts tightened and loosened 5 times):		P
	- rated current (A)	16 A	—
	- copper conductor of the largest cross-sectional area (mm ²) (Table 4)	2,5 mm ²	—
	- type of conductor (solid or stranded)	Solid	—
	- torque (Nm) (Table 7 or appropriate Figures 9, 10 or 11)	0,8 Nm	—
	During the test: terminals do not work loose and show no damage		P
12.2.9	Clamping screws or nuts of earthing terminals: adequately locked against accidental loosening; not possible to loosen them without the aid of a tool		P
12.2.10	Earthing terminals: no risk of corrosion		P
	Body of brass or other metal no less resistant to corrosion		P
	The body is a part of a frame or enclosure of aluminium alloy: precautions are taken to avoid the risk of corrosion		N/A
12.2.11	Pillar terminals: distance <i>g</i> no less than the value specified in Figure 9: req. (mm); meas. (mm)		N/A
	Mantle terminals: distance <i>g</i> no less than the value specified in Figure 2: req. (mm); meas. (mm)		N/A
12.3	Screwless-type terminals for external copper conductors		N/A
12.3.1	Screwless-type terminals of the type suitable for:		N/A
	- rigid copper conductors only, or		N/A
	- both rigid and flexible copper conductors (tests carried out with rigid and then repeated with flexible conductors)		N/A

IEC 60884-1			
Clause	Requirement + Test	Result - Remark	Verdict
12.3.2	Screwless-type terminals provided with two clamping units each allowing the proper connection of rigid or of rigid and flexible conductors having nominal cross-sectional areas from 1,5 up to 2,5 mm ² (Table 8)		N/A
	Two conductors to be connected: each conductor introduced in a separate clamping unit		N/A
12.3.3	Screwless-type terminals allow the conductor to be connected without special preparation		N/A
12.3.4	Parts of screwless-type terminals intended for carrying current of materials as specified in 26.5		N/A
12.3.5	Screwless-type terminals clamp specified conductors with sufficient contact pressure without undue damage to the conductor		N/A
	Conductor clamped between metal surfaces		N/A
12.3.6	It is clear how the connection and disconnection of the conductors is to be made		N/A
	Disconnection of a conductor require an operation, other than a pull, so that can be made manually with or without a general-purpose tool		N/A
	It is not possible to confuse the opening intended for the use of a tool with the opening intended for the conductor		N/A
12.3.7	Screwless-type terminals intended for the interconnection of two or more conductors:		N/A
	- the clamping of one of the conductors is independent of the clamping of the other conductor(s)		N/A
	- during the connection or disconnection, the conductors can be connected or disconnected either at the same time or separately		N/A
	- each conductor introduced in a separate clamping unit.		N/A
	- it is possible to clamp securely any number of conductors up to the maximum as designed. No. of conductors; Nom. cross-sectional area (mm ²):		N/A
12.3.8	Screwless-type terminals of fixed socket-outlets: adequate insertion obvious and over-insertion prevented		N/A
12.3.9	Screwless-type terminals properly fixed to the socket-outlets		N/A
	Not work loose when conductors are connected or disconnected		N/A

IEC 60884-1			
Clause	Requirement + Test	Result - Remark	Verdict
	Self-hardening resins used to fix terminals not subject to mechanical stress		N/A
12.3.10	Screwless-type terminals withstand mechanical stresses occurring in normal use	See appended table 12.3.10	N/A
	During application of the pull conductor not come out of the terminal		N/A
	Additional test with apparatus shown in Figure 13	See appended table 12.3.10	N/A
	During the test: conductors not moved noticeably in the clamping unit		N/A
	After these tests: neither terminals nor clamping means have worked loose and conductors show no deterioration		N/A
12.3.11	Screwless-type terminals withstand electrical and thermal stresses occurring in normal use	See appended table 12.3.11	N/A
	After the test: inspection show no changes		N/A
	Repetition of mechanical strength test according to 12.3.10	See appended table 12.3.11	N/A
	During application of the pull conductor not come out of the terminal		N/A
	Additional test with apparatus shown in Figure 13	See appended table 12.3.11	N/A
	During the test: conductors not moved noticeably in the clamping unit		N/A
	After these tests: neither terminals nor clamping means have worked loose and conductors show no deterioration		N/A
12.3.12	Screwless-type terminals: connected rigid solid conductor remains clamped, even when deflected during normal installation	See appended table 12.3.12	N/A
12.4	Insulation piercing terminals (IPT)		N/A
	See Annex F		—
12.5	Crimped connections in accessories		N/A
12.5.1	All conductors strands deformed from their original cross-section form in the effective crimp zone		N/A
	No cracks throughout the metal barrel are present		N/A
	For closed barrels:		N/A
	<ul style="list-style-type: none"> any burr does not bigger than half of the thickness of the original material 		N/A
	For open barrels:		N/A

IEC 60884-1			
Clause	Requirement + Test	Result - Remark	Verdict
	<ul style="list-style-type: none"> the height of the burr does not bigger than the thickness of the original material 		N/A
	<ul style="list-style-type: none"> the width of the burr does not bigger than half of the thickness of the original material 		N/A
	Compliance is checked by analysis of the crimped connection; documentation of the manufacturer and test of 12.5.2		N/A
12.5.2	Pull-out test for crimped connections for accessories		N/A
	- suitable mechanical strength		N/A
	- six specimen prepared by the manufacturer		N/A
	- more than 24 h before the test		N/A
	- crimp height measured/documented before the test		N/A
	- pull force applied axially to the termination		N/A
	- any cable clamping device that is not part of termination: inoperative		N/A
	- pull-out force measured/documented (minimum value defined by manufacturer)		N/A
	Test conducted applying tension to the specimen:		N/A
	- until the conductor is pulled out of the crimp barrel		N/A
	- or the conductor breaks		N/A
13	CONSTRUCTION OF FIXED SOCKET-OUTLETS		P
13.1	General		P
	Socket-contact assembly have sufficient resilience to ensure adequate contact pressure on plug pins		P
	Part of socket-contact assembly ensure metallic opposing contacts at least on two sides of each pins		P
13.2	Requirements for socket-contacts and pins		P
	- resistant to corrosion and abrasion		P
	Socket-contact and pin(s) of socket-outlet which are made of copper or copper alloy, as specified in 26.5, are considered as complying with this requirement		P
	Compliance by inspection or by chemical analysis		N/A
	The pin(s) of socket-outlets so constructed in such a way that the mechanical strength of the pin(s) does not depend on the plastic material		N/A

IEC 60884-1			
Clause	Requirement + Test	Result - Remark	Verdict
	Compliance is checked by inspection and in case of doubt by the tests of 14.2 and Clause 21 on a new set of specimens without plastic		N/A
13.3	Insulating linings, barriers and the like		P
	adequate mechanical strength		P
13.4	Connection of conductors		P
	Socket-outlets constructed as to permit:		P
	- easy introduction into the terminal and reliable connection of the conductors in the terminals, except for lead wires of pilot lights		P
	- easy fixing of the main part to a wall or in a mounting box	Claws used	P
	- correct positioning of the conductors		P
	- adequate space between the underside of the main part and the surface on which the main part is mounted		P
	- adequate space between the sides of the main part and the enclosure (cover or box)		P
	Socket-outlets having screwless-type terminals or insulation-piercing terminals, constructed that the connecting and/or disconnecting means of the screwless-type terminals cannot be activated by the conductors during and after installation		N/A
	Compliance checked by inspection / test		N/A
	- a solid copper conductor having the smallest cross-sectional area, as specified in 12.3.2 (mm ²) is pushed into the terminal		N/A
	- the test probe 1 of IEC 61032 is pushed against the connecting mean with 120 N, in the direction opposite to the mounting direction (Fig. 15a).		N/A
	During the application of force, the conductor is pulled, 1 min, in the direction of the longitudinal axis of the conductor space.		N/A
	The conductor do not come out.		N/A
	Allowed exert the resulting force if the axes deviates by more than 20° (Fig. 15b)		N/A
	- If the angle is greater than 60° or		N/A
	- If it is not possible to exert a force onto the connecting/disconnecting device, the product is deemed to comply with the requirements without further tests.		N/A

IEC 60884-1			
Clause	Requirement + Test	Result - Remark	Verdict
	In addition, socket-outlets classified to 7.2.4.1 Design A: permit easy positioning and removal of the cover or cover plate, without displacing the conductors or activating the connecting and/or disconnecting means of screwless-type terminals or insulation-piercing terminals.		P
	Compliance is checked by inspection and by an installation test with conductors of the largest nominal cross-sectional area specified in Table 3 4 (mm ²)		N/A
13.5	Engagement of plugs		P
	Socket-outlets designed that full engagement of associated plugs is not prevented by any projection from their engagement face		P
	Gap between the engagement face of the socket-outlet and the plug: not exceed 1 mm	No projections	P
13.6	Covers provided with bushings for the entry holes for the pins		N/A
	- not possible to remove them from the outside or for them to become detached inadvertently from the inside when the cover is removed		N/A
13.7	Protection against electric shock provided by covers, cover plates		P
13.7.1	- held in place at two or more points by effective fixings		N/A
	- fixed by means of a single fixing, for example, by a screw, provided that they are located by another means (captive)	2 screws used	P
	Fixings of covers or cover-plates of socket-outlets of design A serve to fix the main parts: there are means to maintain the base in position, even after removal of the covers or cover-plates		N/A
13.7.2	Covers or cover-plates whose fixings are of the screw-type:		P
	Compliance checked by inspection only		P
13.7.2.3	Covers or cover-plates whose fixing is not dependent on screws and whose removal is obtained by applying a force in a direction approximately perpendicular to the mounting / supporting surface (Table 14)		N/A
	Compliance checked, when their removal may give access, with the standard test finger		N/A
	a) to live parts: by the test of 24.13		N/A

IEC 60884-1			
Clause	Requirement + Test	Result - Remark	Verdict
	b) to non-earthed metal parts separated from live parts in such a way that creepage distances and clearances have the values shown in Table 26: by the test of 24.14		N/A
	c) only to: <ul style="list-style-type: none"> • parts of insulating material, or • earthed metal parts, or • metal parts separated from live parts in such a way that creepage distances and clearances have twice the values shown in Table 26, or • live parts of SELV circuits not greater than 25 V AC or 60 V DC: by the test of 24.15 		N/A
13.7.4	Covers or cover-plates the fixing of which is not dependent on screws and whose removal is obtained by using a tool, in accordance with the manufacturer's instructions given in an instruction sheet or in other documentation		N/A
	Compliance checked, when their removal may give access, with the standard test finger (Table 14)		N/A
	a) to live parts: by the test of 24.13		N/A
	b) to non-earthed metal parts separated from live parts in such a way that creepage distances and clearances have the values shown in Table 26, by the test of 24.14		N/A
	c) only to: <ul style="list-style-type: none"> • parts of insulating material, or • earthed metal parts, or • metal parts separated from live parts in such a way that creepage distances and clearances have twice the values shown in Table 26, or • live parts of SELV circuits not greater than 25 V AC or 60 V DC: by the test of 24.15 		N/A
13.8	Cover-plate intended for a socket-outlet with earthing contact		P
	- not interchangeable with a cover-plate intended for a socket-outlet without earthing contact		P
13.9	Surface-type socket-outlets		N/A
	- no free openings in their enclosures		N/A
	- drain holes, small gaps, cables, earthing contacts, grommets, membranes, knockouts are neglected provided they do not compromise the declared IP rating		N/A
	- have not bare current-carrying strips at the back		N/A

IEC 60884-1			
Clause	Requirement + Test	Result - Remark	Verdict
13.10	Means for mounting the socket-outlet		P
	Screws or other means for mounting the socket-outlet on a surface in a box or enclosure: easily accessible from the front		P
	Fixing means do not serve any other fixing purpose		P
13.11	Multiple socket-outlets with a common base		P
	- provided with fixed links for the interconnection of the contacts in parallel		P
	- fixing of the links independent from the connection of the supply wires		P
13.12	Multiple socket-outlets with separate bases		N/A
	Multiple socket-outlets, comprising separate bases: correct position of each base ensured		N/A
	Fixing of each base independent of the fixing of the combination to the mounting surface		N/A
13.13	Mounting plate of surface-type socket-outlets		N/A
	- adequate mechanical strength		N/A
13.14	Lateral strain imposed by equipment		P
	Socket-outlets withstand the lateral strain imposed by equipment likely to be introduced into them		P
	Socket-outlets 16 A 250 V: test made 4 times with the socket-outlet turned through 90°, 5 N for 1 min (device shown in fig. 16)		P
	During the test: device not become disengaged from the socket-outlet		P
	After the test:		P
	- socket-outlets comply with the requirements of sub-clauses 22.2 and 22.3		P
13.15	Lampholders		N/A
	Socket-outlets are not an integral part of lampholders		N/A
13.16	Surface-type socket-outlets having IP code higher than IP20		N/A
	Surface-type socket-outlets having an IP code higher than IP20 are according to their IP classification when installed in accordance with the manufacturer's instructions and without a plug in engagement		N/A

IEC 60884-1			
Clause	Requirement + Test	Result - Remark	Verdict
	Surface-type socket-outlets having an IP code from IPX4 to IPX6 have provision for opening a drain hole		N/A
	Socket-outlets with a drain hole: drain hole is not less than 5 mm in diameter, or 20 mm ² in area with a width and a length of not less than 3 mm		N/A
	Drain hole: effective		N/A
	Lid springs (if any): of corrosion-resistant material (bronze or stainless steel)		N/A
13.17	Earthing pins		N/A
	Earthing pins: adequate mechanical strength		N/A
	Not solid pins: compliance checked by inspection and by test of 14.2 made after the tests of clause 21		N/A
13.18	Rotation of contacts		P
	Earthing contacts, phase contacts and neutral contacts: locked against rotation		P
	- when the product is ready for the wiring do not possible to be removed without the use of a tool		P
13.19	Metal strips of the earthing circuit		P
	Metal strips of the earthing circuit: no burrs which might damage the insulation of the supply conductors		P
13.20	Installation in boxes		P
	Socket-outlets to be installed in a box: designed that the conductor ends can be prepared after the box is mounted in position, but before the socket-outlet is fitted in the box		P
13.21	Inlet openings		N/A
	Inlet openings: allow the introduction of the conduit or the sheath of the cable		N/A
	Surface-type socket-outlets:		N/A
	the conduit or sheath of the cable can enter at least 1 mm into the enclosure		N/A
	inlet opening for conduit entries, or at least two of them if there are more than one, capable of accepting conduit sizes of 16, 20, 25 or 32 according to IEC 60423:2007 or a combination of at least two of any of these sizes		N/A

IEC 60884-1			
Clause	Requirement + Test	Result - Remark	Verdict
	inlet opening for cable entries capable of accepting cables having the dimensions specified in Table 15 or be as specified by the manufacturer: rated current (A); Limits of external dimensions of cable min/max (mm)		N/A
13.22	Fixing of membranes (grommets)		N/A
	Membranes (grommets) in inlet openings: reliably fixed and not displaced by the mechanical and thermal stresses occurring in normal use		N/A
	Test on membranes subjected to the ageing treatment specified in 16.1 and assembled in the accessories		N/A
	Accessories placed at (40 ± 2) °C for 2 h. After this period, a force of 30 N applied for 5 s by test probe 11 of IEC 61032. During the test: no deformation		N/A
	Membranes likely to be subjected to an axial pull: axial pull of 30 N applied for 5 s. During the test: membranes not become detached		N/A
	After the test: no harmful deformation, cracks or similar damage		N/A
	Test repeated with membranes not subjected to any treatment		N/A
13.23	Material for membranes		N/A
	Membranes in inlet openings: introduction of the cables into the accessory permitted when the ambient temperature is low		N/A
	Test on membranes not subjected to the ageing treatment specified in 16.1 and assembled in the accessories		N/A
	Accessories kept at (-15 ± 2) °C for 2 h: possibility to introduce cables of the largest diameter through membranes		N/A
	After the test of 13.22 and 13.23: no harmful deformation, cracks or similar damage		N/A
14	CONSTRUCTION OF PLUGS AND PORTABLE SOCKET-OUTLETS		N/A
14.1	Non-rewirable portable accessories		N/A
	flexible cable cannot be separated from the accessory without making it permanently useless		N/A
	Accessory cannot be opened by hand or by using a general purpose tool, for example a screwdriver used as such		N/A
14.2	Mechanical strength of pins of portable accessories		N/A

IEC 60884-1			
Clause	Requirement + Test	Result - Remark	Verdict
	- adequate; compliance by test of clause 24		N/A
	Test for pins not solid (made after test of clause 21): force of 100 N exerted on the pin, according to Figure 17, for 1 min by means of a steel rod Ø 4,8 mm		N/A
	During the application of the force: reduction of the dimension of the pin do not exceed 0,15 mm		N/A
	After removal of the rod: dimensions of the pin not changed by more than 0,06 mm		N/A
14.3	Fixing of pins and contacts of portable accessories		N/A
	- locked against rotation;		N/A
	- not removable without dismantling the accessory		N/A
	- adequately fixed in the body of the accessory		N/A
	Earthing contacts, phase contacts and neutral contacts of socket-outlets: not removable unless with the aid of a tool, after dismantling the socket-outlet		N/A
	Earthing or neutral pins or contacts of accessories: not possible to arrange in an incorrect position		N/A
	In addition, for single portable socket-outlets compliance is checked by the test of 24.3		N/A
	Pins of portable accessories constructed in such a way that their mechanical strength does not depend on the internal plastic material		N/A
	Compliance is checked by inspection; in case of doubt by the tests of 14.2 and 21, on a new set of specimens with pins without internal plastic material		N/A
	Surfaces of portable accessories pins smooth and free from burrs or sharp edges and other irregularities which could cause damage or excessive wear to corresponding socket contacts or shutters		N/A
14.4	Construction of socket-contacts assemblies		N/A
	Socket-contact assemblies: sufficient resilience		N/A
	Parts of socket-contact assemblies:		N/A
	- ensure metallic contact at least on two opposing sides of each pin		N/A
	Contact pressure of the contact tube does not depend on soldered connection only		N/A
14.5	Resistance to corrosion and abrasion of pins and socket-contacts		N/A
	- resistant to corrosion and abrasion		N/A

IEC 60884-1			
Clause	Requirement + Test	Result - Remark	Verdict
	Socket contacts and pin(s) of socket-outlets, which are made of copper or copper alloy, as specified in 26.5, are considered as complying with this requirement.		N/A
14.6	Enclosures of rewirable portable accessories		N/A
	- completely enclose the terminals and the ends of flexible cable		N/A
	- conductors can be properly connected		N/A
	Construction is unlikely that:		N/A
	- cores not pressed together so as not to cause damage		N/A
	- cores of live conductor not pressed against accessible metal parts		N/A
	- core of earthing conductor not pressed against live parts		N/A
14.7	Screws and nuts of rewirable portable accessories		N/A
	- terminal screws or nuts cannot become loose and fall out of position and establish an electrical connection between live parts and earthing terminal or metal parts		N/A
14.8	Strain relief		N/A
	Rewirable portable accessories with earthing contact: ample space for slack of earthing		N/A
	Test: it is possible to house the loop formed by the earthing conductor owing to its surplus length		N/A
	Non-rewirable non-moulded-on accessories with earthing contact: current-carrying conductors stressed before the earthing conductor if the flexible cable slips in its anchorage		N/A
14.9	Risk of electric shock from loose wires		N/A
14.9.1	Terminals of rewirable portable accessories and terminations of non-rewirable portable accessories: located and shielded that loose wires do not present a risk of electric shock		N/A
	Non-rewirable moulded-on portable accessories: provided with means to prevent loose wires of a conductor from reducing the minimum isolation distance requirements		N/A
14.9.2	Test for rewirable accessories		N/A
	- 6 mm free wire of a conductor connected to a live terminal do not touch any accessible metal part or able to emerge from the enclosure		N/A

IEC 60884-1			
Clause	Requirement + Test	Result - Remark	Verdict
	- free wire of a conductor connected to an earthing terminal do not touch a live part		N/A
14.9.3	Test for non-rewirable non-moulded on accessories with a free wire of length equivalent to the maximum designed stripping length declared by the manufacturer plus 2 mm		N/A
	- free wire of a conductor connected to a live termination do not touch any accessible metal part or reduce creepage distance and clearance below 1,5 mm to the external surface		N/A
	- free wire of a conductor connected to an earth termination do not touch any live part		N/A
14.9.4	Verification for non-rewirable moulded on accessories		N/A
	- there are means to prevent stray wires reducing the minimum distance through insulation to external accessible surface below 1,5 mm		N/A
14.10	Cord anchorage		N/A
	Rewirable portable accessories		N/A
	- clear how the relief from strain and prevention of twisting is intended to be effected		N/A
	- cord anchorage, or at least part of it, integral with or securely fixed to one of the component parts of the plug or portable socket-outlet		N/A
	- makeshift methods not used		N/A
	- cord anchorage suitable for the different types of flexible cable which may be connected to it; screws, if any: not serve to fix any other component		N/A
	- cord anchorages: of insulating material or provided with an insulating lining fixed to the metal parts		N/A
	- metal parts of cord anchorages, including clamping screws: insulated from the earthing circuit		N/A
14.11	Removal of covers, cover plates or parts of them		N/A
	Rewirable portable accessories and non-rewirable non-moulded on portable accessories: it is not possible to remove covers, cover-plates or parts of them intended to ensure protection against electric shock without the use of a tool		N/A
	- fixing of screw-type: inspection		N/A
	- fixing not depend on screws / removal give access to live parts: test of 24.13.4		N/A

IEC 60884-1			
Clause	Requirement + Test	Result - Remark	Verdict
14.12	Bushings		N/A
	Covers of portable socket-outlets: bushings for entry holes for the pins not removable from the outside or detachable inadvertently from the inside		N/A
14.13	Screws intended to allow access to interior of the accessory		N/A
	- captive		N/A
14.14	Engagement face of plugs		N/A
	- no projections		N/A
14.15	Engagement in portable socket-outlets		N/A
	- full engagement not prevented by any projection		N/A
14.16	Portable accessories having IP code higher than IP20		N/A
	enclosed according to their IP classification		N/A
	Plugs having an IP code higher than IP20, with the exception of the engagement face, adequately enclosed when fitted with a flexible cable as for normal use		N/A
	Portable socket-outlet having an IP code higher than IP20 adequately enclosed when fitted with a flexible cable as for normal use and without a plug in engagement		N/A
	Lid springs: of corrosion-resistant material.....:		N/A
14.17	Portable socket-outlets having means for suspension		N/A
	- means for suspension from a wall or other mounting surfaces: do not allow access to live parts		N/A
	No free openings between space intended for suspension means by which the socket-outlet is fixed to the wall, or to another mounting surface and live parts	see 24.12.1; 24.12.2; 24.12.3	N/A
14.18	Combinations of portable accessories and switches, circuit-breakers or other devices		N/A
	- comply with relevant individual IEC International Standards, if a relevant combined product standard does not exist		N/A
14.19	Lampholders		N/A
	Portable accessories are not integral part of lampholders		N/A
14.20	Plugs for equipment of class II		N/A
	- rewirable or non-rewirable		N/A

IEC 60884-1			
Clause	Requirement + Test	Result - Remark	Verdict
	- if part of a cord set: provided with a connector for equipment of class II		N/A
	- if part of a cord extension set: provided with a portable socket-outlet for equipment of class II		N/A
14.21	Components incorporated in accessories		N/A
	Components such as switches and fuses, incorporated in accessories: comply with the applicable parts of the relevant IEC International Standard		N/A
	Components incorporated in portable accessories:		N/A
	- so rated, or so protected, that overloading of either the component or the plug or the socket-outlet portion cannot occur in normal use		N/A
	Requirements for switches incorporated in portable accessories are detailed in Annex C	See appended Table 14.22	N/A
	For portable socket-outlets and rewirable plugs:		N/A
	- the incorporated overcurrent protective device in the accessory have a rated current equal to or less than the rated current of the accessory		N/A
	Any other component(s), such as switches or control devices, have a rated current not less than (rated current referred to resistive load):		N/A
	- the rated current of the accessory or		N/A
	- the rated current of the incorporated overcurrent protective device		N/A
	For non-rewirable plugs, any other incorporated component(s), such as switches or control devices, have a rated current not less than:		N/A
	- the test current for the combination of the accessory and the cable as indicated in Table 18, for Clause 21, or		N/A
	- the rated current of the incorporated overcurrent protective device		N/A
	Any incorporated component(s) have a rated voltage not less than the rated voltage of the accessory		N/A
	Compliance is checked by inspection and, if necessary, by testing the component according to the relevant IEC International Standard		N/A
14.22	Plug which is an integral part of plug-in equipment		N/A
14.22.1	Plug-in equipment: not cause overheating of the pins or impose undue strain on fixed socket-outlets		N/A

IEC 60884-1			
Clause	Requirement + Test	Result - Remark	Verdict
	Plugs with rating above 16 A and 250 V: not integral part of other equipment		N/A
	Tests of 14.2.2 and 14.22.3 for two-pole plugs, with or without earthing contact, with rating up to and including 16 A and 250 V		N/A
14.22.2	- Plug of equipment inserted into a fixed socket-outlet complying with this standard		N/A
	- Socket-outlet being connected to a supply voltage equal to 1,1 times the highest rated voltage of the equipment (V)		N/A
	Temperature rise of the pins after 1 h does not exceed 45 K		N/A
14.22.3	- Equipment inserted into a fixed socket-outlet complying with this standard. The socket-outlet is pivoted about a horizontal axis through the axis of the live socket-contacts at a distance of 8 mm behind its engagement face and parallel to it.		—
	- additional torque applied to the socket-outlet in order to maintain the engagement face in the vertical plane does not exceed 0,25 Nm		N/A
14.23	Gripping		N/A
	Plugs can easily be withdrawn by hand from the relevant socket-outlets		N/A
	Gripping surfaces are so designed that the plug can be withdrawn without having to pull the flexible cable		N/A
14.24	Membranes in inlet openings of portable accessories		N/A
	- meet the requirements of 13.22 and 13.23		N/A
14.25	Rewirable portable socket-outlets which can be fixed		N/A
	Rewirable portable socket-outlets which can be assembled and wired for normal use, after their rear part has been fixed onto a surface, comply both with the requirements for portable socket-outlets and with the following additional requirements for surface fixed socket-outlets		N/A
	- provision for earthing: 11.2, 11.3, 11.6;		N/A
	- terminals and terminations: 12.2.1;		N/A
	- construction of fixed socket-outlets: Clause 13;		N/A
	- resistance to ageing, protection provided by enclosures, and resistance to humidity: 16.2.2, 16.2.3;		N/A
	- temperature rise: Clause 19;		N/A
	- mechanical strength: Clause 24;		N/A
	- resistance to heat: Clause 25;		N/A

IEC 60884-1			
Clause	Requirement + Test	Result - Remark	Verdict
	- creepage distances, clearances and distances through sealing compound: Clause 27;		N/A
	- resistance of insulating material to abnormal heat, to fire and to tracking: 28.1.2, glow-wire test		N/A
14.26	Requirements for shutters in portable socket-outlets		N/A
	Portable socket-outlets: provided with shutters		N/A
15	INTERLOCKED SOCKET-OUTLETS		N/A
	Socket-outlet interlocked with a switch:		N/A
	- plug cannot be inserted into or completely withdrawn from the socket-outlet while the socket-contacts are live		N/A
	- socket-contacts cannot be made live until a plug is almost completely in engagement		N/A
16	RESISTANCE TO AGEING, PROTECTION PROVIDED BY ENCLOSURES, AND RESISTANCE TO HUMIDITY		P
16.1	Resistance to ageing		P
	Accessories are resistant to ageing		P
	For accessories having a lid, the lid is closed during the test		P
	Portable socket-outlets: the plug of the same system having the same rated current as the socket-outlet inserted into the socket-outlet during the test		N/A
	Accessories subjected to a test in a heating cabinet at $(70 \pm 2) ^\circ\text{C}$ for seven days (168 h)		P
	After the tests, the specimens show:		P
	- no crack visible with normal or corrected vision without additional magnification		P
	- no sticky or greasy material		P
	- no trace of cloth (forefinger pressed with 5 N)		P
	- no damage		P
	- portable socket-outlets: contact pressure of the contact assembly checked as specified in subclause 22.3 with the single-pin gauge. It do not fall out from the contact assembly within 30 s.		N/A
	- fixed socket-outlet: test repeated on a new set of specimen. Contact pressure of the contact assembly checked as specified in subclause 22.2.3 with the single-pin gauge. It do not fall out from the contact assembly within 30 s.		P

IEC 60884-1			
Clause	Requirement + Test	Result - Remark	Verdict
16.2	Protection provided by enclosures		P
16.2.1	General		P
	Enclosures provide protection against access to hazardous parts, harmful effects due to ingress of solid foreign objects and water, in accordance with the IP designation of the accessory	IP20	P
16.2.2	Protection against access to hazardous parts and against harmful effects due to ingress of solid foreign objects		P
16.2.2.1	General		P
	Accessories and their enclosures provide a degree of protection against access to hazardous parts and against harmful effects due to ingress of solid foreign objects		P
	Fixed socket-outlets: mounted as in normal use on a vertical surface		P
	Flush-type and semi-flush type socket-outlets: mounted in an appropriate box according to the manufacturer's instructions		P
	Accessories with screwed glands or membranes fitted and connected with cables within the connecting range specified in Table 4.		N/A
	- largest cross-sectional area (mm ²); type of cable (Table 20)	/	-
	- smallest cross-sectional area (mm ²); type of cable (Table 20)	/	-
	Glands tightened with a torque equal to 2/3 of the torque applied during the test of 24.7 (Nm)	/	-
	Screws of the enclosure tightened with a torque equal to 2/3 of the torque given in Table 7 (Nm) ..	/	-
16.2.2.2	Protection against access to hazardous parts		P
	Appropriate test performed as specified in IEC 60529 (see also clause 10)	IP20	P
16.2.2.3	Protection against harmful effects due to ingress of solid foreign objects		P
	Appropriate test performed as specified in IEC 60529	IP20	P
	Test on accessories with IP5X (considered to be of category 2): dust not penetrated in a quantity to interfere with satisfactory operation or to impair safety		N/A
	Test on accessories with IP6X (considered to be of category 1): dust do not penetrate		N/A

IEC 60884-1			
Clause	Requirement + Test	Result - Remark	Verdict
16.2.3	Protection against harmful effects due to ingress of water		N/A
	Accessories and their enclosures provide a degree of protection against harmful effects due to ingress of water in accordance with their IP classification	IP20	N/A
	Appropriate test performed as specified in IEC 60529 under the following conditions:		N/A
	- Flush-type and semi flush-type socket-outlets: fixed in a vertical test wall according to Figure 18 a) representing the intended use of the flush and semi flush-type socket-outlets, using an appropriate box in accordance with the manufacturer's instruction		N/A
	- when manufacturer's instruction specify: 'accessory suitable to be installed on a rough wall', test wall according to Figure 18 b) or Figure 18 c) is used.		N/A
	- test wall: with bricks or plastic; smooth surfaces		N/A
	- box mounted in the test wall: fit tight against the wall		N/A
	- sealing material do not influence sealing properties of specimen tested		N/A
	- Surface-type socket-outlets mounted as for normal use in a vertical position		N/A
	- fitted with cables or conduits or both in accordance with the manufacturer's instructions		N/A
	- cables have conductors of the largest and smallest nominal cross-sectional area (Table 4)		N/A
	- test wall: smooth surface (Figure 18 a)		N/A
	- end of cable sheath, raised 2 mm		N/A
	- entry of cable: below		N/A
	Accessories IPX3 IPX4		N/A
	- test device Figure 19		N/A
	- rotation axis horizontal and		N/A
	- on the mounting plane of the test wall		N/A
	- specimen centre in the middle of rotation axis		N/A
	- Portable socket-outlets tested on a flat, horizontal surface in a position as in normal use		N/A
	- no strain of flexible cable		N/A
	- fitted with flexible cables (Table 20)		N/A

IEC 60884-1			
Clause	Requirement + Test	Result - Remark	Verdict
	- cables have conductors of the largest and smallest nominal cross-sectional area (Table 4)		N/A
	- screws of enclosure tightened with a torque equal to 2/3 of the torque given in Table 7 (Nm)		N/A
	- glands tightened with a torque equal to 2/3 of the torque applied during the test of 24.7 (Nm)		N/A
	- cable glands not filled with sealing compound		N/A
	Accessory with drain holes opened during the test: any accumulation of water proved by inspection		N/A
	- socket-outlet with IP code less than IPX5 with drain holes, one is opened in the lowest position		N/A
	- socket-outlet with IP code equal or greater than IPX5 with drain holes, they not opened		N/A
	Socket-outlets tested without a plug in engagement		N/A
	Plugs tested when in full engagement with:		N/A
	- a fixed socket-outlet		N/A
	- a portable socket-outlet		N/A
	of the same system / same degree of protection against harmful effects due to ingress of water		-
	Accessory with drain holes opened during the test: any water entered does not accumulate; it drains away without doing any harm to the complete assembly		-
	Specimens withstand an electric strength test specified in 17.3 which is started within 5 min of completion of the IP test		N/A
16.3	Resistance to humidity		P
	Accessories proof against humidity which may occur in normal use		P
	Compliance checked by a humidity treatment carried out in a humidity cabinet containing air with relative humidity maintained between 91 % and 95 %		P
	Specimens kept in the cabinet for:		P
	- two days (48 h) for accessories having IPX0		P
	- seven days (168 h) for accessories having IP>X0		N/A
	After this treatment the specimens comply with the insulation resistance measurement and the electric strength test specified in Clause 17		P

IEC 60884-1			
Clause	Requirement + Test	Result - Remark	Verdict
17	INSULATION RESISTANCE AND ELECTRIC STRENGTH		P
17.1	General		P
	Insulation resistance and electric strength of accessories: adequate Pilot light or electronic devices pole: disconnected		P
17.2	Test for measuring the insulation resistance		P
17.2.1	Insulation resistance: measured 1 min after application of 500 V DC		P
17.2.2	Socket-outlet: the insulation resistance is measured consecutively	See appended Table 17.2.2	P
17.2.3	Plugs: the insulation resistance is measured consecutively	See appended Table 17.2.3	N/A
17.3	Electric strength test		P
	A sine-wave form voltage applied for 1 min	See appended Table 17.3	P
18	OPERATION OF EARTHING CONTACTS		P
	Earthing contacts provide adequate contact pressure and not deteriorate in normal use		P
	Compliance checked by the tests of clauses 19 and 21		P
19	TEMPERATURE RISE		P
19.1	General		P
	Accessories constructed that they comply with the following temperature rise test		P
	Plugs and socket-outlets tested according to 19.2, except:		P
	Fixed socket-outlets of a socket-outlet and fused plug system: 19.3 Fused plugs tested according to IEC 60884-2-1		N/A
	Accessories with incorporated components not covered by other parts of IEC 60884 series: 19.4		N/A
	Crimped connections: 19.5.1		N/A
	Fixed socket-outlets incorporating pilot lights: 19.5.2		N/A
	Non-rewirable accessories are tested as delivered		N/A
	Rewirable accessories fitted with polyvinyl chloride conductors: nominal cross sectional area Table 16		P
	Tightening torque: 2/3 of that specified in 12.2.8		P
	Conductors length not less than 1 m		P

IEC 60884-1			
Clause	Requirement + Test	Result - Remark	Verdict
	Test plug conductors same nom. cross-section of the socket-outlet under test		P
	The conductor from each terminal not less than 1 m		P
	For a two-pole plug, length between terminals do not less than 2 m		N/A
	Flush-mounted accessories mounted in flush-mounted boxes made of pinewood filled around with plaster		P
	- flush-mounted boxes made of pinewood filled around with plaster		P
	- box front edge does not protrude; no more 5 mm below the front surface		P
	- test assembly dried at least seven days		P
	- at least 25 mm of wood surrounding the plaster		P
	- thickness of plaster 10 - 15 mm around the box		P
	- cable entry (sealed) through the top of the box		P
	- length of conductors within the box: 80±10 mm		P
	Surface-type socket-outlets mounted on a wooden block surface, at least 20 mm thick, 500 mm wide/high		N/A
	Other type socket-outlets mounted:		N/A
	- according to manufacturer's instructions, or		N/A
	- position give most onerous condition		N/A
	Draught-free environment		P
	Non-rewirable accessories: minimum influence in accessing its terminations		N/A
	Three poles or more accessory: current passed through the phase contacts		P
	Separate test through neutral and adjacent phase contact		P
	Separate test through earthing and nearest phase contact		P
	In the case of multiple socket-outlets, the test is carried out on one socket-outlet of each type and current rating with the test current as specified in Table 18 passed through that one socket-outlet		P

IEC 60884-1			
Clause	Requirement + Test	Result - Remark	Verdict
	Multiple socket-outlet consisting of pre-wired single socket-outlets intended to be mounted in one single box: test current on the socket-outlet farthest from the main terminals		P
	The temperature rise of the terminals, terminations and clamping units according to Figure 20 determined by means of thermocouples do not exceed 45 K		P
	External parts of insulating material: temperature rise determined for 25.4		P
	Socket-outlets test: test plug brass pins with dimensions corresponding standard sheet		P
	Plug test: draught-free environment, on a wooden block surface, at least 20 mm thick, 500 mm wide/high		N/A
	- clamping units of Figure 20 used		N/A
	- supply cable of figure 20: nominal cross-sectional area appropriate (Table 16); at least length 1 m		N/A
	- screw on pin tightened 0,8 Nm		N/A
	- plugs with lateral / resilient earthing contacts; test performed with a socket-outlet:		N/A
	- complying with IEC 60884-1		N/A
	- average characteristics		N/A
	- earthing pin with minimum size		N/A
19.2	Test for plugs and socket-outlets		P
	- socket-outlet with a test plug inserted; AC or DC current, specified in Table 18, passed for 60+5/0 min	See appended Table 19.2	P
	- plug: an AC or DC current, as specified in Table 18, passed for 60+5/0 min	See appended Table 19.2	N/A
	- HL plugs and socket-outlets: AC or DC as specified in Table 18 is passed, for sufficient time to reach the steady-state value, or 4 hours, whichever is shorter	See Annex I / Table I.19.2	N/A
19.3	Test for fixed socket-outlets in fused plug system		N/A
	For fixed socket-outlets of a socket-outlet and fused plug system, an AC or DC current as specified in Table 18 is passed for 60+5/0 min as follows		N/A
	a) For a single socket-outlet the plug is inserted into the socket-outlet and 70 % of the test current is passed through the plug		N/A

IEC 60884-1			
Clause	Requirement + Test	Result - Remark	Verdict
	The balance of the total test current is passed, simultaneously through a looped connection, connected to the socket-outlet terminals		N/A
	The total nominal load on the supply cable is passed for 60+5/0 min.		N/A
	b) For a multiple socket-outlet a plug is inserted into one socket-outlet and 70 % of the test current is passed		N/A
	A second plug is inserted into another socket-outlet and the balance of the total test current is passed simultaneously through this plug :	See appended Table 19.3	N/A
	The total nominal load on the supply cable is passed for 60+5/0 min.		N/A
	Components: - connected in series are short circuited		N/A
	- connected in parallel are disconnected		N/A
19.4	Test for accessories with incorporated components not covered by other parts of IEC 60884 series		N/A
	Socket-outlets and rewirable plugs with incorporated components are tested by the following tests 1) and 2):		N/A
	<u>Test 1)</u> with a current which is equal to the test current as indicated in Table 18, for Clause 19. Incorporated components: - connected in series are short circuited; - connected in parallel are disconnected.	See appended Table 19.4	N/A
	<u>Test 2)</u> incorporated components in series, with a current which is equal to the rated current, or the rated current of the component(s) whichever is the lower.	See appended Table 19.4	N/A
	<u>Test 2)</u> incorporated components in parallel, with a current which is equal to the rated current, or with the component working as in normal use.	See appended Table 19.4	N/A
	When the incorporated components need to be supplied for their correct functioning, the test is made at the rated voltage.		N/A
	Non-rewirable plugs with incorporated components are tested by the following tests 3) and 4):		N/A

IEC 60884-1			
Clause	Requirement + Test	Result - Remark	Verdict
	<p><u>Test 3</u>) with a current which is equal to the test current for the combination of the plug and the cable as indicated in Table 18, for Clause 19.</p> <ul style="list-style-type: none"> - Incorporated components connected in series are short circuited. - Incorporated components connected in parallel are disconnected. 	See appended Table 19.4	N/A
	<p><u>Test 4</u>) incorporated components connected in series, with:</p> <ul style="list-style-type: none"> - a current which is equal to the test current for the combination of the plug and the cable as indicated in Table 18, for Clause 21, or - the rated current of the component(s), whichever is the lower. 	See appended Table 19.4	N/A
	<p><u>Test 4</u>) Incorporated components connected in parallel, with:</p> <ul style="list-style-type: none"> - a current which is equal to the test current for the combination of the plug and the cable as indicated in Table 18, for Clause 21, with the incorporated component working as in normal use. 	See appended Table 19.4	N/A
	When the incorporated components need to be supplied for their correct functioning, the test is made at the rated voltage.		N/A
	Tests 1) - 3), the temperature rise of terminals / terminations / clamping units according to Figure 20 determined by thermocouples do not exceed 45 K		N/A
	Tests 2) - 4), the temperature rise do not exceed the permissible values given in Table 101 of IEC 60669-2-1:2021 for Clause 17		N/A
	Non-rewirable accessories: minimum influence in accessing its terminations		N/A
19.5	Additional tests		N/A
19.5.1	Temperature rise test for accessories with crimped connections		N/A
19.5.1.1	General		N/A
	Accessories with crimped connections: AC or DC as specified in Table 18 is passed, for sufficient time to reach the steady-state value, or 4 hours, whichever is shorter	See appended Table 19.5.1.2	N/A
	Crimped connections with flexible conductors used in accessories withstand, without harmful effect, mechanical, electrical, and thermal stresses occurring when subjected to cyclic loads.		N/A

IEC 60884-1			
Clause	Requirement + Test	Result - Remark	Verdict
	Tests performed on six connections of each crimp construction, taken from three specimens by new non-moulded on or non-assembled specimens.	See appended Table 19.5.1.2	N/A
	Accessories shall be tested in a draught-free environment.		N/A
19.5.1.2	Test		N/A
	<ul style="list-style-type: none"> - Live pins of the plug inserted in the clamping units having the dimensions specified in Figure 20. - flexible conductors selected according to Table 16 at least 1 m long to be connected to the source. - Screw of the clamping unit tightened with a torque of 0,8 Nm. 	See appended Table 19.5.1.2	N/A
	<ul style="list-style-type: none"> - Plug fixed on a vertical wooden sheet, being at least 20 mm thick. - pins of the plugs are maintained in a horizontal position. - Distance between specimens simultaneously under test is 150 mm. 		N/A
	<ul style="list-style-type: none"> - Crimped connections of socket-outlets are tested in open air (without their enclosures) fitted with cable having a minimum length of 1 m as provided by the manufacturer. - Temperature rise measured on the conductors as close as possible to the crimped connection, not more than 10 mm away from the entrance of the crimping barrel. - Contact tube connected by a means which does not affect the test results, e.g. welding, soldering or a clamping unit, to a flexible conductor selected according to column 2 for rigid conductors (solid or stranded) for fixed accessories of Table 16. 	See appended Table 19.5.1.2	N/A
	<ul style="list-style-type: none"> - Length of the conductor connected: 1 m. - the crimped connection is not affected by the mounting of thermocouples on the conductors and flexible conductors on the socket contacts. 		N/A
	<p>For each cycle, an overload AC or DC current as given in Table 17 according to the nominal cross-section area of the conductor connected is passed for 45 +1/0 min through the poles (no earthing circuit).</p> <p>The accessory then be left without current for 15 min (0, -1 min).</p>	See appended Table 19.5.1.2	N/A
	Number of cycles is 250 or 500 depending on the measurement results.	See appended Table 19.5.1.2	N/A

IEC 60884-1			
Clause	Requirement + Test	Result - Remark	Verdict
	The temperature rises at the clamping units of the plug, or the conductor of the socket-outlet is measured for each cycle within the last 5 min before the end of the current-carrying period.	See appended Table 19.5.1.2	N/A
	The accessory is declared compliant when the following conditions are fulfilled.		N/A
	a) The temperature rises measurement of each crimped connection do not exceed 45 K.	See appended Table 19.5.1.2	N/A
	b) The average of the six temperature rises measurements of the crimped connections under testing recorded at the 250th cycle do not exceed 35 K.	See appended Table 19.5.1.2	N/A
	c) A linear trend-line of all six measurements is calculated and drawn through the measurement points from the 50th to the 250th cycle. The value given by each trend-line at the 250th cycle do not exceed the value given on the trend-line at the 50th cycle by more than 5 K.	See appended Table 19.5.1.2	N/A
	When c) is not fulfilled the test is extended to 500 cycles with the following additional compliance conditions.	See appended Table 19.5.1.2	N/A
	d) The average of the six temperature rises measurements of the crimped connections under testing recorded at the 500th cycle do not exceed 35 K.	See appended Table 19.5.1.2	N/A
	e) A linear trend-line of all six measurements is calculated and drawn through the measurement points from the 250th to the 500th cycle. The value given by each trend-line at the 500th cycle do not exceed the value given on the trend-line at the 250th cycle by more than 10 K. The linear trend-line is calculated according to the formula given the standard	See appended Table 19.5.1.2	N/A
19.5.2	Additional test for fixed socket-outlets incorporating pilot-lights		N/A
	Fixed socket-outlets incorporating pilot-lights: in normal use temperature rise of accessible surfaces do not excessive		N/A
	Test:		N/A
	- Fixed socket-outlets mounted / connected as 19.1		N/A
	- Pilot light supplied at rated voltage.		N/A
	- The fixed socket-outlets loaded at rated current.		N/A
20	BREAKING CAPACITY		P

IEC 60884-1			
Clause	Requirement + Test	Result - Remark	Verdict
	Accessories have adequate breaking capacity		P
	Pilot lights disconnected or removed		P
	Compliance checked by testing:		P
	- socket-outlets;	See appended Table 20	P
	- plugs with pins which are not solid	See appended Table 20	N/A
	Rewirable accessories fitted with polyvinyl chloride conductors: nom. section Table 16		P
	Failure of the shutters: the test repeated with operations done by hand.		N/A
	Rate of strokes per minute and the period during which the test current is passed closed as possible to the indicated values.		P
	Socket-outlets tested using a test plug with brass pins having the dimensions of the corresponding standard sheets. As far as the extremities of the sleeves are concerned, it is sufficient that their dimensions are within the tolerances given in the relevant standard sheet.		P
	Material of the brass pins of the test plug contain 58 % copper and their micro-composition is homogeneous.		P
	The ends of round pins are rounded.		P
	Plugs are tested using a fixed socket-outlet having as near to-average characteristics as can be selected.		N/A
	For accessories with a rated voltage lower than or equal to 250 V and a rated current lower than or equal to 32 A, the length of the stroke of test apparatus is between 50 mm and 60 mm.		P
	15 strokes per minute for other accessories.		P
	Test voltage: 1,1 times the rated voltage.	275 V	P
	Test current: 1,25 times the rated current.	20 A	P
	Periods during which the test current is passed from the insertion of the plug until subsequent withdrawal:		P
	- accessories with rated current ≤ 16 A: 1,5 0+0,5 s		P
	- accessories with rated current > 16 A: 3 0+0,5 s		N/A
	Accessories are tested using an alternating current with $\cos \varphi = 0,6 \pm 0,05$.		P
	No current passed through the earthing circuit.		P

IEC 60884-1			
Clause	Requirement + Test	Result - Remark	Verdict
	The test is carried out with the connections shown in Figure 23.		P
	Multiple socket-outlets: test carried out on one socket-outlet of each type and current rating		P
	During the test: no sustained arcing occur		P
	After the test:		P
	- specimens show no damage impairing their further use;		P
	- entry holes for the pins do not show any damage which may impair the safety		P
21	NORMAL OPERATION		P
	Accessories withstand without excessive wear or other harmful effect, the mechanical, electrical and thermal stresses occurring in normal use		P
	Compliance checked by testing:		P
	- socket-outlets;	See appended Table 21	P
	- plugs with resilient earthing socket-contacts;	See appended Table 21	N/A
	Test pins (during socket-outlet test) and fixed socket-outlets (during plug test for plugs with earthing socket-contacts or with pins not solid): - replaced after 4500 and 9000 strokes.		P
	Socket-outlets with shutters: Test performed according to the procedure specified in Figure 24; point at which the test program has begun (1, 2, 3)		N/A
	Socket-outlets tested using a test plug with brass pins having the dimensions of the corresponding standard sheets. As far as the extremities of the sleeves are concerned, it is sufficient that their dimensions are within the tolerances given in the relevant standard sheet.		P
	Material of the brass pins of the test plug contain 58 % copper and their micro-composition is homogeneous.		P
	The ends of round pins are rounded.		P
	Plugs are tested using a fixed socket-outlet having as near to-average characteristics as can be selected.		N/A
	Specimens are tested with an AC as specified in Table 18, at rated voltage, in a circuit with $\cos \varphi = 0,8 \pm 0,05$. The tolerance for the test voltage is +5 / 0 %		P

IEC 60884-1			
Clause	Requirement + Test	Result - Remark	Verdict
	The plug is inserted and withdrawn from the socket-outlet 5 000 times (10 000 strokes) at a rate of:		P
	- 30 strokes per minute for accessories having a rated current up to and including 16 A and a rated voltage up to and including 250 V		P
	- 15 strokes per minute for other accessories.		N/A
	Test current passed:		P
	- during each insertion and withdrawal of the plug ($I_n \leq 16$ A)		P
	- during alternate insertion and withdrawal, the other insertion and withdrawal being made without current flowing ($I_n > 16$ A)		N/A
	Periods of passage test current, from insertion of the plug until subsequent withdrawal: – accessories with rated current ≤ 16 A: 1,5+0,5/0 s – accessories with rated current > 16 A: 3 +0,5/0 s	1,5 s	P
	No current is passed through the earthing circuit		P
	The test is carried out with the connections indicated in Clause 20.		P
	Multiple socket-outlets: test carried out on one socket-outlet of each type and current rating		P
	During the test: no sustained arcing occur		P
	After the test the specimens do not show:		P
	- wear impairing their further use;		P
	- deterioration of enclosures, insulating linings or barriers;		P
	- damage to the entry holes for the pins, that might impair proper working;		P
	- loosening of electrical or mechanical connections;		P
	- seepage of sealing compound		N/A
	Shuttered socket-outlets: tested again according to Clause 10.5 performed at ambient temperature, with gauges of Figures 7 and 8		N/A
	Specimens comply with Clause 19. Test current as specified in Table 18		P

IEC 60884-1			
Clause	Requirement + Test	Result - Remark	Verdict
	Specimens withstand an electric strength test carried out according to 17.3, the test voltage being reduced with 500 V for accessories having a rated voltage exceeding 130 V and with 250 V for accessories having a rated voltage up to and including 130 V		P
	Pins which are not solid: test according to 14.2		N/A
22	FORCE NECESSARY TO WITHDRAW THE PLUG		P
22.1	General		P
	Construction of accessory allows the easy insertion and withdrawal of the plug, and prevent the plug from working out of the socket-outlet in normal use		P
	Compliance for socket-outlets:		P
	- the maximum force necessary to withdraw the test plug from the socket-outlet is not higher than that specified in Table 19	See appended Table 22	P
	- the minimum force necessary to withdraw a single pin gauge from the individual contact assembly is not lower than that specified in Table 19	See appended Table 22	P
	- the maximum force to operate the shutters is not higher than that specified in 22.4 (30 N)		N/A
	Compliance for plugs with resilient earthing contact assemblies:		N/A
	- the maximum force necessary to withdraw a single pin gauge from the individual, resilient, earthing contact assembly is not higher than that specified in Table 19	See appended Table 22	N/A
	- the minimum force necessary to withdraw a single pin gauge from the individual earthing contact assembly is not lower than that specified in Table 19	See appended Table 22	N/A
22.2	Verification of the maximum withdrawal force		P
22.2.1	Test for socket-outlets		P
	Use of apparatus shown in Figure 25		P
	Test plug (multi-pin): ten insertions / withdrawal		P
	Test plug (multi-pin) inserted again; a carrier E with a principal mass F and supplementary mass G being attached to it by a clamp D		P

IEC 60884-1			
Clause	Requirement + Test	Result - Remark	Verdict
	Force exerted by the supplementary mass G equal to one-tenth of the maximum withdrawal force shown in Table 19		P
	The principal mass is hung, and the supplementary mass fall onto the principal mass from a height of 50 mm		P
	The plug did not remain in the socket-outlet	See appended Table 22	P
22.2.2	Test for plugs with resilient earthing contact assemblies		N/A
	Test pin gauge, Fig. 26, applied to the resilient earthing contact assembly		N/A
	Pin gauge of hardened steel; surface roughness $0,6 \div 0,8 \mu\text{m}$ over its active length		N/A
	Pins: diameter of maximum dimensions		N/A
	Force exerted by the gauge as specified in Tab. 19		N/A
	The test pin gauge inserted into / withdrawal from the earthing contact ten times. It is inserted again and did not remain in the contact assembly		N/A
22.3	Verification of the minimum withdrawal force		P
	Test pin gauge, Fig. 26, applied to each individual contact of the socket-outlet or the plug		P
	Shutters, if any, inoperative		N/A
	Pin gauge of hardened steel; surface roughness $0,6 \div 0,8 \mu\text{m}$ over its active length		P
	Pins: diameter of minimum dimensions and sufficient length		P
	Force exerted by the gauge as specified in Tab. 19		P
	Socket-outlet intended to accept plugs with different nominal dimensions: the smallest one is used		N/A
	Rating of the plug with the smallest dimensions for the pin is used		N/A
	The test pin gauge inserted into the contact assembly: shall not fall from the contact within 30 s	See appended Table 22.3	P
22.4	Force necessary to operate the shutter when inserting the plug		N/A
	Socket-outlet fixed to a mounting plate		N/A
	Axes are vertical		N/A
	Entry holes upwards		N/A
	Test plug corresponding standard sheet is used		N/A

IEC 60884-1			
Clause	Requirement + Test	Result - Remark	Verdict
	The test plug and the supplementary mass enter in the holes under its own weight: force exerted, 30 N		N/A
	Contact within 5 s		N/A
	Electrical indicator used to show the contact		N/A
23	FLEXIBLE CABLES AND THEIR CONNECTIONS		N/A
23.1	General		N/A
	Rewirable plugs and rewirable portable socket-outlets are provided with a cord anchorage such that the conductors are relieved from strain and twisting; the covering is protected from abrasion		N/A
	Sheath of flexible cable is clamped within the cord anchorage		N/A
	In non-rewirable plugs and non-rewirable portable socket-outlets the cable is maintained in position and the terminations are relieved from strain and twisting		N/A
	Sheath of flexible cable is maintained inside the accessory		N/A
23.2	Cord anchorage		N/A
	Effectiveness of the retention of the cable by the cord anchorage		N/A
	Non-rewirable accessories:		N/A
	- tested as delivered; new specimens		N/A
	Rewirable accessories:		N/A
	- tested with cable of smallest cross sectional area		N/A
	- tested with cable of largest cross sectional area		N/A
	- conductors introduced into the terminals		N/A
	- terminal screws tightened sufficiently to prevent the position of the conductors from easily changing		N/A
	- cord anchorage used in the normal way: clamping screws tightened with torque two-thirds of that specified in Table 7		N/A
	- with specimen reassembled, the component parts are fit snugly		N/A
	- it is not possible to push the flexible cable appreciably into the sample		N/A
	- the axis of the flexible cable is vertical		N/A
	Test:		N/A
	Flexible cable is subjected 100 times to a pull of:		N/A

IEC 60884-1			
Clause	Requirement + Test	Result - Remark	Verdict
	<ul style="list-style-type: none"> • 50 N if the rated current is 2,5 A • 60 N if the rated current is above 2,5 A, but not more than 20 A; the rated voltage is up to and including 250 V • 80 N if the rated current is above 2,5 A, but not more than 20 A; the rated voltage is above 250 V • 100 N if the rated current greater than 20 A 	See appended Table 23.2	N/A
	Pulls applied each time for 1 s without jerks		N/A
	Pulls exert simultaneously on all parts of the cable		N/A
	Immediately afterwards, the flexible cable is subjected for 1 min to a torque as specified in Table 21	See appended Table 23.2	N/A
	After the test:		N/A
	Displacement ≤ 2 mm	See appended Table 23.2	N/A
	Rewirable accessories: end of conductors have not moved noticeably in the terminals		N/A
	Non-rewirable accessories: no break in the electrical connections		N/A
	Measurements of the longitudinal displacement made at a distance of 20 mm from the end of the specimen, or the flexible cable guard, while the flexible cable is subjected to the pull		N/A
	In addition, for rewirable accessories having a rated current up to and including 16 A: manual test to check that they are suitable for fitting with the appropriate cable, as shown in Table 22.		N/A
	Type of flexible cable; number of conductors, nominal cross-sectional area (mm ²), maximum dimensions for flexible cables (mm)		—
23.3	Flexible cable of non-rewirable accessories		N/A
	Non-rewirable plugs and non-rewirable portable socket-outlets are provided with a flexible cable complying with IEC 60227, IEC 60245, IEC 62821, or IEC 63010		N/A
	Flexible cables have the same number of conductors as there are poles in the plug or socket-outlet		N/A
	Conductor connected to the earthing contact is identified by the colour combination green/yellow		N/A
23.4	Protection of cable entrance in the accessories		N/A

IEC 60884-1			
Clause	Requirement + Test	Result - Remark	Verdict
	Non-rewirable accessories: designed that the flexible cable is protected against excessive bending		N/A
	Guards of insulating material and fixed in reliable manner		N/A
	Helical metal springs: do not used		N/A
	Flexing test (new specimens)		N/A
	Apparatus shown in Fig. 28		N/A
	Force applied: – 20 N for accessories with flexible cables having a nominal cross-sectional area exceeding 0,75 mm ² – 10 N for other accessories	See appended Table 23.4	N/A
	Current equal to the rated current of the accessory, or the following, whichever is the lower, is passed through the conductors: – 16 A for accessories with flexible cables having a nominal cross-sectional area larger than 0,75 mm ² – 10 A for accessories with flexible cables having a nominal cross-sectional area of 0,75 mm ² – 2,5 A for accessories with flexible cables having a nominal cross-sectional area less than 0,75 mm ²	See appended Table 23.4	N/A
	The voltage between the conductors is equal to the rated voltage of the specimen	See appended Table 23.4	N/A
	The oscillating member is moved through an angle of 90° (45° on either side of the vertical). Number of flexings: 10 000		N/A
	Rate of flexing 60/min.		N/A
	Specimens with circular section flexible cables are turned through 90° in the oscillating member after 5000 flexings; specimens with flat flexible cables are only bent in a direction perpendicular to the plane containing the axes of the conductors.		N/A
	During the test: no interruption of the test current and no short-circuit between conductors		N/A
	After the test: guard no separated from the body, insulation shows no sign of abrasion or wear, broken strands become no accessible		N/A
24	MECHANICAL STRENGTH		P
24.1	General		P
	Accessories, surface mounting boxes, screwed glands and shrouds have adequate mechanical strength		P

IEC 60884-1			
Clause	Requirement + Test	Result - Remark	Verdict
24.2	Impact test with pendulum hammer		P
	Fixed socket-outlets, portable multiple socket-outlets and surface-type mounting boxes: hammer test described in IEC 60068-2-75 (test EHA), equivalent mass of 250 g	See appended Table 24.2	P
	Height of fall and parts of enclosures subjected to the impacts specified in Table 23	See appended Table 24.2	P
	After the test: <ul style="list-style-type: none"> - no damage impairing further use - live parts no become accessible as defined in Clauses 10.2 / 10.5 - live parts no damage as to impair Cr / Cl distances as defined in Clause 27 		P
	After the test on a lens (window for pilot lights) the lens may be cracked and/or dislodged, but it is not possible to touch live parts with the: <ul style="list-style-type: none"> - test probe B (IEC 61032) under the conditions stated in 10.2 - test probe 11 (IEC 61032) under the conditions stated in 10.2, but with a force of 10 N - steel wire of Fig. 8, applied with a force of 1 N, for accessories with increased protection 		N/A
	In case of doubt, it is verified that it is possible to remove and replace external parts such as boxes, enclosures, covers and cover-plates, without these parts or their insulating lining being broken.		N/A
24.3	Tumble barrel test		N/A
	Rewirable portable accessories fitted with the flexible cable specified in 23.2		N/A
	with the smallest nominal cross-sectional area specified in Table 4		N/A
	A free length of approximately 100 mm measured from the outer end of the guard		N/A
	Terminal screws and assembly screws are tightened with a torque equal to two-thirds of that specified in Table 7		N/A
	Non-rewirable portable accessories tested as delivered		N/A
	The flexible cable cut so that a free length of about 100 mm projects from the accessory		N/A

IEC 60884-1			
Clause	Requirement + Test	Result - Remark	Verdict
	Portable single socket-outlets and plugs: subjected to test Ec: Rough handling shocks, primarily for equipment-type specimens, procedure 2 of IEC 60068-2-31; number of falls:		N/A
	After the test:		N/A
	- no part become detached or loosened;		N/A
	- pins no become so deformed that the plug cannot be introduced into a socket-outlet and also fails to comply with the requirements of 9.1 and 10.4		N/A
	- pins no turn when a torque of 0,4 Nm is applied for 1 min in one direction, then for 1 min in the opposite direction		N/A
	Shutters of socket-outlets tested again according to 10.5 performed at ambient temperature		N/A
24.4	Test for fixed socket-outlets with a main part intended to be mounted directly on a surface		N/A
	Main parts of surface-type socket-outlets are first fixed to a cylinder of rigid steel sheet		N/A
	Cylinder radius equal to 4,5 times the distance between fixing holes (no less than 200 mm)		N/A
	Axes of the holes perpendicular to the axis of the cylinder		N/A
	Axes of the holes parallel to the radius through the centre of the distance between the holes		N/A
	Fixing screws of the base are gradually tightened		N/A
	Torque applied: - 0,5 Nm for screws having a thread diameter up to and including 3 mm - 1,2 Nm for screws having a larger thread diameter.		N/A
	The main parts of socket-outlets are then fixed in a similar manner to a flat steel sheet		N/A
	During and after the tests: no damage		N/A
24.5	Impact test at low temperature		N/A
	Portable single / multiple socket-outlets and plugs subjected to an impact test by means of an apparatus as shown in Figure 30		N/A
	- apparatus, positioned on a pad of sponge rubber 40 mm thick		N/A
	- placed together with the specimens in a freezer at a temperature of $(-15 \pm 2) ^\circ\text{C}$, for at least 16 h.		N/A

IEC 60884-1			
Clause	Requirement + Test	Result - Remark	Verdict
	At the end of this period, the following test is carried out inside the freezer: each specimen, in turn, is placed in the normal position of use as shown in Figure 30, and a weight is allowed to fall from a height of 100 mm. The mass of the falling weight is $(1\ 000 \pm 2)$ g.		N/A
	After the test: - no damage impairing further use - live parts no become accessible as defined in Clauses 10.2 / 10.5 live parts no damage as to impair Cr / Cl distances as defined in Clause 27		N/A
24.6	Compression test		N/A
	Specimens subjected to a compression test		N/A
	- temperature of the pressure plate, of the base and of the specimens: 23 ± 2 °C - force applied: 300 N. - specimens are first placed in position a), as shown in Figure 6 - force is applied for 1 min. - they are then placed in position b), - again, subjected to the force for 1 min		N/A
	The specimens are removed from the test apparatus and are left to recover for 15 min.		N/A
	After the test: - no damage impairing further use - live parts no become accessible as defined in Clauses 10.2 / 10.5 live parts no damage as to impair Cr / Cl distances as defined in Clause 27		N/A
24.7	Torque test for cable glands		N/A
	Screwed cable glands fitted with a cylindrical metal rod		N/A
	Cable glands are then tightened by means of a suitable spanner; the torque shown in Table 24 being applied for 1 min.		N/A
	- diameter of test rod (mm)		N/A
	- type of material (metal / moulded)		N/A
	- torque (Nm)		N/A
	After the test: no damage of glands and enclosures of the specimens		N/A

IEC 60884-1			
Clause	Requirement + Test	Result - Remark	Verdict
24.8	Abrasion test on insulating sleeves of plug pins		N/A
	Plug pins provided with insulating sleeves: subjected to the test by means of the apparatus shown in Figure 31.		N/A
	Force on the pin: 4 N		—
	Number of movements: 20 000		—
	Rate of operations: 30 movements per minute		—
	After the test: no damage of pins, insulating sleeve do not have punctured or rucked up		N/A
24.9	Mechanical tests on shutters		N/A
	Shuttered socket-outlets: mechanical test carried out on specimens submitted to the normal operation test according to clause 21		N/A
	Force (40 N / 75 N) applied for 1 min against the shutter of an entry hole by means of one pin (N).....:		N/A
	Pin did not come in contact with live parts		N/A
	After the test: no damage		N/A
	A plug complying with corresponding standard sheet is inserted and withdrawn 5 times and the shutters shall operate as intended.		N/A
24.10	Test for multiple portable socket-outlets		N/A
	Mechanical test for multiple portable socket-outlet: 8 falls on concrete floor with the specimens arranged as shown in Figure 32		N/A
	After the test: - no part have become detached or loosened - no damage impairing further use - live parts no become accessible as defined in Clauses 10.2 / 10.5 live parts no damage as to impair Cr / CI distances as defined in Clause 27		N/A
	Accessories having IP code higher than IPX0 submitted again to the tests as specified in 16.2		N/A
	Shutters of socket-outlets tested again according to 10.5 performed at ambient temperature		N/A
24.11	Retention test for pins		N/A
	Plugs: pull test to verify the fixation of pins in the body of the plug (new specimens)		N/A

IEC 60884-1			
Clause	Requirement + Test	Result - Remark	Verdict
	A pull P equal to the maximum withdrawal force (table 19) applied for 1 min on each pin in turn, after the specimen has been placed at $(70 \pm 2) ^\circ\text{C}$ for 1 h (N)		N/A
	After the test: displacement of pins in the body of the plug ≤ 1 mm (mm)		N/A
24.12	Mechanical test for means for suspension of portable socket-outlets		N/A
24.12.1	Barriers, between the space intended for the suspension means fixed to the mounting surface and the live parts, likely to be subjected to mechanical strain when the portable socket-outlet is suspended on a mounting surface, tested as follows:		N/A
	A steel rod, diameter 3 mm, hemispherical end radius 1,5 mm, is pushed perpendicular to the mounting surface, for 10 s against the barrier, the force being equal to 1,5 times the maximum plug withdrawal force (Table 19)		N/A
	Rod did not pierce the barrier		N/A
24.12.2	The portable socket-outlet, fitted with a flexible cable, is suspended on the mounting surface, by the same rod as 24.12.1, length sufficient to touch the rear of the barrier		N/A
	A pull equal to the force specified in 23.2 for checking the anchorage is applied to the flexible cable for 10 s (N)		N/A
	The portable socket-outlet means for suspension on a mounting surface, do not break in a way which allows live parts to become accessible to the test probe B of IEC 61032		N/A
24.12.3	The portable socket-outlet is suspended on the mounting surface, using a round head screw with shank diameter 3 mm, and is subjected to a pull test with the maximum withdrawal force specified, for the corresponding plug, in Table 19, applied without jerks		N/A
	The pull force is applied for 10 s perpendicular to the engagement face of the socket-outlet giving the greatest strain on the suspension means.		N/A
	The portable socket-outlet means for suspension on a wall do not break in a way which allows live parts to become accessible to the test probe B of IEC 61032.		N/A
24.13	Tests on covers, cover-plates or parts of them according to 13.7.3 a)		N/A

IEC 60884-1			
Clause	Requirement + Test	Result - Remark	Verdict
24.13.1	Accessories mounted as for normal use to check the forces necessary to retain or remove covers, cover-plates or parts of them	Screw used for front plate	N/A
	Flush-type socket-outlets are fixed in appropriate mounting boxes		N/A
	Rims of the boxes are flush with the walls		N/A
	Covers or cover-plates are fitted		N/A
	Plugs / portable socket-outlets are fixed so that the force can be applied to the cover, cover-plates or parts of them		N/A
	Locking means which can be operated without the aid of a tool: unlocked.		N/A
24.13.2	Fixed socket-outlets: verification of the retention of covers or cover-plates		N/A
	Forces are gradually applied perpendicular to the mounting surface. The resulting force acting on the centre of the covers, cover-plates, or parts of them is, respectively:		N/A
	<ul style="list-style-type: none"> • 40 N, for covers, cover-plates or parts of them complying with the tests of 24.16 and 24.17, or • 80 N, for other covers, cover-plates or parts of them. (Table 14)		N/A
	Force applied for 1 min. The covers or cover-plates do not come off.		N/A
	Test repeated on new specimens. The cover or cover-plate being fitted on the wall. A sheet of hard material, (1 ± 0,1) mm thick, fitted around the supporting frame.		N/A
	After the test, the specimens do not show damage impairing their future use.		N/A
24.13.3	Fixed socket-outlets: verification of the removal of covers or cover-plates	Screw used for front plate	N/A
	Force 120 N gradually applied, perpendicular to the mounting/supporting surfaces, to covers, cover-plates or parts of them by means of a hook placed in turn in each of the grooves, holes, spaces or the like, provided for removing them.		N/A
	Covers or cover-plates come off.		N/A

IEC 60884-1			
Clause	Requirement + Test	Result - Remark	Verdict
	Test carried out 10 times on separable parts. Removal force applied to the grooves, holes, or the like provided for removing the separable parts, distributing the application points.		N/A
	Test repeated on new specimens. The cover or cover-plate being fitted on the wall. A sheet of hard material, (1 ± 0,1) mm thick, fitted around the supporting frame.		N/A
	After the test, the specimens do not show damage impairing their future use.		N/A
24.13.4	Plugs / portable socket-outlets: Force 80 N gradually applied and maintained for 1 min to covers, cover-plates or parts of them. Other parts of the accessory, fixed		N/A
	During the test covers, cover-plates or parts of them do not come off.		N/A
	Test repeated with a force of 120 N.		N/A
	a) rewirable plugs / rewirable portable socket-outlets: cover, cover-plate or parts of them may come off during the test, but the specimen show no damage impairing further use.		N/A
	b) non-rewirable / non-moulded-on accessories: during the test, cover, cover-plate or parts of them may come off but the accessories are permanently useless (see 14.1).		N/A
24.14	Tests on covers, cover-plates or parts of them according to 13.7.3 b)		N/A
	Test carried out as described in 24.13, but applying the forces for the purposes of 24.13.2:		N/A
	<ul style="list-style-type: none"> • 10 N, for covers, cover-plates complying with the tests of 24.16 and 24.17 • 20 N, for other covers or cover-plates (Table 14)		N/A
24.15	Tests on covers, cover-plates or parts of them according to 13.7.3 c)		N/A
	Test carried out as described in 24.13, but applying the force of 10 N for all covers or cover-plates for the purposes of 24.13.2 (Table 14)		N/A
24.16	Verification of the outline of covers fixed without screws on a mounting surface or supporting surface		P
	Gauge of Figure 35 pushed toward each side of each cover or cover-plate which is fixed without screws on a mounting or supporting surface		P

IEC 60884-1			
Clause	Requirement + Test	Result - Remark	Verdict
	Face B resting on the mounting/supporting surface, with face A perpendicular to it, the gauge applied at right angles to each side under test.		P
	Distances between face C of the gauge and the outline of the side under test, measured parallel to face B, do not decrease		P
24.17	Verification of grooves, holes and reverse tapers		P
	Gauge of Figure 38, applied with a force of 1 N do not enter more than 1,0 mm from the upper part of any groove, hole or reverse taper, or the like, when the gauge is applied parallel to the mounting / supporting surface and perpendicular to the part under test		P
24.18	Compression test on shrouds of portable socket-outlets		N/A
	Shrouds of portable socket-outlets: compression test at an ambient temperature of $(25 \pm 5) ^\circ\text{C}$		N/A
	Apparatus: two steel jaws, cylindrical face 25 mm radius, width 15 mm, length of 50 mm.		N/A
	Front face of the jaws coincides with the front face of the shroud.		N/A
	Force applied through the jaws: $20 \pm 2 \text{ N}$		N/A
	After 1 min, while the shrouds are still under pressure, dimensions comply with the appropriate standard sheet.		N/A
	Test repeated with the specimen rotated 90°		N/A
25	RESISTANCE TO HEAT		P
25.1	General		P
	Accessories and surface-type mounting boxes are resistant to heat.		P
	Compliance is checked by the relevant tests according to Table 25.		P
25.2	Basic heating test		P
	Specimens kept: heating cabinet, 1h, $100 \pm 2 ^\circ\text{C}$		P
	During the test: - no change impairing their further use; sealing compound, if any, do not flow so live parts are exposed.		P

IEC 60884-1			
Clause	Requirement + Test	Result - Remark	Verdict
	After the test: <ul style="list-style-type: none"> - markings still legible - no access to live parts with probe B of IEC 61032 applied with a force not exceeding 5 N - in particular: live parts no become accessible as defined in Clauses 10.2 / 10.5 live parts no damage as to impair Cr / CI distances as defined in Clause 27		P
25.3	Ball-pressure test at 125 °C		P
	Parts of insulating material necessary to retain current-carrying parts and parts of the earthing circuit in position, as well as parts of the front surface zone, 2 mm wide, surrounding phase and neutral pin entry holes: ball-pressure test at (125 ± 2) °C for 1 h (apparatus shown in Figure 40)	See appended Table 25.2	P
	Part under test placed on a steel plate at least 3 mm thick and in direct contact with it		P
	Surface of the part tested: placed in horizontal position		P
	The hemispherical tip of the test equipment: pressed against the surface with a force of 20 N		P
	Diameter of the impression caused by the ball: not exceed 2 mm.		P
25.4	Ball-pressure test at 70 °C or higher		P
	Parts of insulating material not necessary to retain current-carrying parts and parts of the earthing circuit in position, even though in contact with them: ball pressure test at (70 ± 2) °C, or (40 ± 2) °C plus the temperature rise determined during the test of Clause 19, whichever is the higher	See appended Table 25.3	P
25.5	Compression test		N/A
	Portable accessories: compression test, by means of the apparatus shown in Figure 41 (steel jaws): - 20 N at (80 ± 2) °C for 1 h		N/A
	After the test: <ul style="list-style-type: none"> - no damage impairing further use - in particular: live parts no become accessible as defined in Clauses 10.2 / 10.5 live parts no damage as to impair Cr / CI distances as defined in Clause 27		N/A
26	SCREWS, CURRENT-CARRYING PARTS AND CONNECTIONS		P
26.1	General		P

IEC 60884-1			
Clause	Requirement + Test	Result - Remark	Verdict
	Connections, electrical or mechanical, withstand mechanical stresses		P
	Thread-forming or thread-cutting screws used only if supplied together with the piece in which they are intended to be inserted		N/A
	Thread-cutting screws intended to be used during installation: captive		N/A
	Threaded part torque test	See appended Table 26.1	P
26.2	Correct insertion of screws		N/A
	Screws in engagement with a thread of insulating material: correct introduction into the screw hole or nut ensured		N/A
26.3	Contact pressure of electrical connections		P
	Contact pressure: not transmitted through insulating material other than ceramic, pure mica or other material no less suitable unless there is sufficient resiliency in metallic parts		P
	Designs with flat tinsel cord		N/A
	Connections made by insulation piercing of tinsel cord reliable		N/A
	Compliance checked by inspection, according to relevant parts of Annex F		N/A
26.4	Screws and rivets used both as electrical and mechanical connections		P
	Screws and rivets locked against loosening and/or turning		P
26.5	Material of current-carrying parts		P
	Current-carrying parts: metal having mechanical strength, electrical conductivity and resistance to corrosion adequate		P
	- copper;		N/A
	- alloy containing at least 58 % copper for parts made from cold-rolled sheet or at least 50 % copper for other parts;		P
	- stainless steel containing at least 13 % chromium and not more than 0,09 % carbon		N/A
	- steel with electroplated coating of zinc (ISO 2081), the coating having a thickness of at least: service condition ISO no. (1/2/3); IP code (X0/X4/X5/X6); thickness (µm)		N/A

IEC 60884-1			
Clause	Requirement + Test	Result - Remark	Verdict
	- steel with electroplated coating of nickel and chromium (ISO 1456): the coating having a thickness of at least: service condition ISO no. (2/3/4); IP code (X0/X4/X5/X6); thickness (µm)		N/A
	- steel with electroplated coating of tin (ISO 2093), the coating having a thickness of at least: service condition ISO no. (2/3/4); IP code (X0/X4/X5/X6); thickness (µm)		N/A
	Current-carrying parts subjected to mechanical wear: not of steel with electroplated coating		N/A
	Metals showing a great difference of electrochemical potential with respect to each other: not used in contact with each other.		N/A
26.6	Contacts subjected to sliding actions		P
	Contacts subjected to a sliding action are of metal resistant to corrosion		P
26.7	Thread-forming screws and thread-cutting screws		P
	Thread-forming screws and thread-cutting screws are not used for the connection of current-carrying parts		P
	Thread-forming screws and thread-cutting screws used to provide earthing connection: it is not necessary to disturb the connection and at least two screws are used for each connection		N/A
27	CREEPAGE DISTANCES, CLEARANCES AND DISTANCES THROUGH SEALING COMPOUND		P
27.1	General		P
	Creepage distances, clearances and distances through sealing compound are not less than the values shown in table 26	See appended Table 27.1	P
27.2	Insulating sealing compound		N/A
	Insulating sealing compound does not protrude above the edge of the cavity in which it is contained		N/A
28	RESISTANCE OF INSULATING MATERIAL TO ABNORMAL HEAT, TO FIRE AND TO TRACKING		P
28.1	Resistance to abnormal heat and to fire		P
28.1.1	General		P
	Parts of insulating material exposed to thermal stresses due to electric effects, and the deterioration of which impair the safety of the accessory, do not affected by abnormal heat and by fire.		P
28.1.2	Glow-wire test		P

IEC 60884-1			
Clause	Requirement + Test	Result - Remark	Verdict
	Test performed according to: - IEC 60695-2-10:2021 - IEC 60695-2-11:2021		P
	Parts of insulating material necessary to retain current-carrying parts, and parts of the earthing circuit of fixed accessories in position: test carried out at 850 °C.	See appended Table 28.1.1	P
	Parts of insulating material necessary to retain current-carrying parts, and parts of the earthing circuit of portable accessories in position: test carried out at 750 °C.	See appended Table 28.1.1	P
	Parts of insulating material not necessary to retain current-carrying parts and parts of the earthing circuit in position, even though they are in contact with them: test carried out at 650 °C. Parts needed to retain the earth terminal in position in a box: test carried out at 650 °C.	See appended Table 28.1.1	P
	Test carried out on specimen of a complete accessory		P
	Test carried out on a suitable part cut from of a complete accessory		P
	The specimen has passed the glow-wire test if: – there is no visible flame and no sustained glowing, or if – flames and glowing extinguish within 30 s after removal of the glow-wire.		P
	No ignition of the tissue paper or scorching of the board		P
28.1.3	Test for pins with insulating sleeves		N/A
	Pins provided with insulating sleeves tested by means of the test apparatus as shown in Figure 43.		N/A
	Test temperature maintained for 3 h at $(120 \pm 5) ^\circ\text{C}$ or $180 \pm 5 ^\circ\text{C}$		N/A
	Specimens removed and cooled at room temperature		N/A
	Insulating sleeves of the pins submitted to an impact test: 4 impacts, mass 100 g, height 10 mm		N/A
	No cracks visible on the insulating sleeves		N/A
	Dimensions have not changed		N/A

IEC 60884-1			
Clause	Requirement + Test	Result - Remark	Verdict
28.2	Resistance to tracking		N/A
	Accessories having an IP code higher than IPX0, parts of insulating material retaining live parts in position are of material resistant to tracking	IP20	N/A
	Material designation		N/A
	Check in accordance with IEC 60112		N/A
	Flat surface of the part tested: 15x15 mm		N/A
	Proof-tracking index 175, test solution A, interval between drops of 30 ± 5 s.		N/A
	No flashover or breakdown occurs before 50 drops has fallen.	See appended Table 28.2	N/A
29	RESISTANCE TO RUSTING		P
	Ferrous parts protected against rusting		P
	All grease is removed using a suitable degreasing agent		P
	Parts immersed for 10 min in a 10 % solution of ammonium chloride in water at (20 ± 5) °C		P
	Without drying, but after shaking off any drops, the parts placed for 10 min in a box containing air saturated with moisture at (20 ± 5) °C.		P
	After the parts have been dried for 10 min at (100 ± 5) °C, their surfaces do not show signs of rust		P
30	ADDITIONAL TESTS ON PINS PROVIDED WITH INSULATING SLEEVES		N/A
30.1	General		N/A
	Material of pin-insulating sleeves are resistant to high and low temperature due to: - bad connection conditions - particular conditions of service		N/A
30.2	Pressure test at high temperature		N/A
	Apparatus of Fig. 44, maintained 2 h at (200 ± 5) °C		N/A
	Rectangular blade (Fig. 44a) used for round pins		N/A
	Round blade (Fig. 44b) used for other type pins		N/A
	Specimen placed in position (Fig. 44)		N/A
	Force applied through the blade: 2,5 N		N/A
	Thickness of the insulation measured: before the test (mm); after the test (mm)		N/A

IEC 60884-1			
Clause	Requirement + Test	Result - Remark	Verdict
	Thickness remaining at the point of impression is not reduced by more than 50 % of its original value measured at the start of the test: percentage value (%)		N/A
30.3	Static damp heat test		N/A
	Set of 3 specimens submitted to two damp heat cycles in accordance with IEC 60068-2-30 (variant 2 with a temperature of 40 °C).		N/A
	After the test:		N/A
	- insulation resistance and electric strength test (clause 17)		N/A
	- abrasion test (sub-clause 24.8)		N/A
30.4	Test at low temperature		N/A
	Set of three specimens maintained at (-15 °C ± 2) °C for 24 h		N/A
	After the test:		N/A
	- insulation resistance and electric strength test (clause 17)		N/A
	- abrasion test (sub-clause 24.8)		N/A
30.5	Impact test at low temperature		N/A
	Specimens are subjected to an impact test by means of the apparatus as shown in Figure 45.		N/A
	Mass of the falling weight: 100 ± 1 g		N/A
	Apparatus and specimens, placed on a sponge rubber pad, 40 mm thick, in a freezer at -15 ± 2 °C for 24 h		N/A
	At the end of this period, each specimen in turn, placed in position (Figure 45)		N/A
	Falling weight fall from a height of 100 mm		N/A
	Four impacts applied successively to the same specimen, rotating it through 90° between impacts		N/A
	After the test: no crack of the insulating sleeves		N/A
31	EMC REQUIREMENTS		N/A
31.1	Immunity		N/A
	Operation of accessories within the scope of Standard IEC60884-1, in normal use, is not affected by electromagnetic disturbances		—
	No test required		—

IEC 60884-1			
Clause	Requirement + Test	Result - Remark	Verdict
	Accessory with incorporated active electronic circuit: additional requirements on EMC fulfilled according to the relevant products standards		N/A
	- incorporated active electronic circuit :		N/A
	- relevant products standards :		N/A
31.2	Emission		N/A
	Accessories within the scope of Standard IEC60884-1 are intended for continuous use; in normal use they do not generate electromagnetic disturbances		—
	Accessory with incorporated active electronic circuit: additional requirements on EMC fulfilled according to the relevant products standards		N/A
	- incorporated active electronic circuit :		N/A
	- relevant products standards :		N/A
32	ELECTROMAGNETIC FIELDS (EMF) REQUIREMENTS		N/A
	Accessories within the scope of Standard IEC60884-1 are intended for continuous use; in normal use they do not generate an additional electromagnetic field beside the one originating from the flowing current		—
	No test required		—
	Accessory with incorporated active electronic circuit: additional requirements on EMF fulfilled according to the relevant products standards		N/A
	- incorporated active electronic circuit :		N/A
	- relevant products standards :		N/A

IEC 60884-1 - TABLES				
Clause	Requirement + Test		Result - Remark	Verdict
12.2.5	TABLE: test with apparatus shown in Figure 13 (screw-type terminals)			P
	rated current (A)	:	16 A	—
	type of conductors	:	<u>rigid solid</u> / <u>rigid stranded</u> / <u>flexible</u>	—
	smallest/largest cross-sectional area (Table 4)(mm ²):	:	1,5 mm ² – 2 x 2,5 mm ²	—
	number of conductors	:	2	—
	nom. diameter of thread (mm); torque Table 7 (Nm) :	:	3,4 mm; 0,8 Nm	—
Cross-sectional area (mm ²)	Diameter of bushing hole per Table 10 (mm)	Height H per Table 10 (mm)	Mass (kg) per Table 10	Verdict
Rigid solid 1,5 mm ²	6,5 mm	260 mm	0,4 kg	P
Rigid solid 2,5 mm ²	9,5 mm	280 mm	0,7 kg	P
Flexible 1,5 mm ²	6,5 mm	260 mm	0,4 kg	P
Flexible 2,5 mm ²	9,5 mm	280 mm	0,7 kg	P
supplementary information:				

12.2.6	TABLE: pull test (screw-type terminals)			P
	rated current (A)	:	16 A	—
	smallest/largest cross-sectional area (Table 4)(mm ²):	:	1,5 mm ² – 2 x 2,5 mm ²	—
	nominal diameter of thread (mm); torque 2/3 per Table 7 (Nm)	:	3,4 mm; 0,53 Nm	—
Cross-sectional area (mm ²)	Number of conductors	Type of conductors (rigid solid / rigid stranded / flexible)	Pull per Table 5 applied for 1 min (N)	Verdict
1,5 mm ²	1	Rigid solid	40 N	P
2,5 mm ²	1	Rigid solid	50 N	P
1,5 mm ²	2	Rigid solid	40 N	P
2,5 mm ²	2	Rigid solid	50 N	P
1,5 mm ²	1	Flexible	40 N	P
2,5 mm ²	1	Flexible	50 N	P
1,5 mm ²	2	Flexible	40 N	P
2,5 mm ²	2	Flexible	50 N	P
supplementary information:				

IEC 60884-1 - TABLES					
Clause	Requirement + Test		Result - Remark	Verdict	
12.2.7	TABLE: tightening test (screw-type terminals)			P	
	rated current (A)		16 A	—	
	nominal diameter of thread (mm); torque 2/3 per Table 7 (Nm)		3,40 mm; 0,53 Nm	—	
	Largest cross-sectional area per Table 6 (mm ²)	Permissible number of conductors ⁽¹⁾	Type of conductors (rigid solid / rigid stranded / flexible)	Number of wires and nominal diameter of wires per Table 6	Verdict
	2,5 mm ²	2	Rigid solid	1 x 1,78 mm	P
	2,5 mm ²	2	Flexible	50 x 0,25 mm	P
supplementary information:					
⁽¹⁾ terminals intended for looping-in 2 or 3 conductors					

12.3.10	TABLE: mechanical strength test (screwless-type terminals)				N/A	
	rated current (A)				—	
	largest/smallest cross-sectional area (Table 8(mm ²)) :				—	
	Number of connection (after that conductor subjected to a pull of 30 N for 1 min) / disconnection	Type of conductor (solid / rigid stranded / flexible)	Cross-sectional area (mm ²)	Verdict		
	TABLE: test with apparatus shown in Figure 13					
	Cross-sectional area (mm ²) per Table 10	Type of conductor (solid / rigid stranded / flexible per Table 10	Diameter of bushing hole per Table 10 (mm)	Height H per Table 10 (mm)	Mass (kg) per Table 10 (mm)	Verdict
supplementary information:						

12.3.11	TABLE: electrical and thermal strength test (screwless-type terminals)				N/A
Test a)	Test carried out for 1 h connecting rigid solid conductors				
	test current per Table 11 (A)				—
	nominal cross-sectional area (mm ²)				—
	Screwless-type terminal number	Voltage drop (mV)		Required voltage drop (mV)	
	1			≤ 15	
	2			≤ 15	
	3			≤ 15	
	4			≤ 15	

IEC 60884-1 - TABLES							
Clause	Requirement + Test				Result - Remark		Verdict
5				≤ 15			
Test b)	Temperature cycles test carried out on terminals subjected to Test a):						
	test current per Table 11 (A)						—
	nominal cross-sectional area (mm ²)						—
	allowed voltage drop (mV)				≤ 22,5 mV or 2 times 24 th cycle value (mV)		—
Screwless-type terminal number	1	2	3	4	5	Verdict	
voltage drop after 24 th cycle							
voltage drop after 48 th cycle							
voltage drop after 72 nd cycle							
voltage drop after 96 th cycle							
voltage drop after 120 th cycle							
voltage drop after 144 th cycle							
voltage drop after 168 th cycle							
voltage drop after 192 nd cycle							
12.3.10	TABLE: mechanical strength test (screwless-type terminals)						N/A
	rated current (A)						—
	largest/smallest cross-sectional area (Table 7)(mm ²):						—
Number of connection (after that conductor subjected to a pull of 30 N for 1 min) / disconnection		Type of conductor (solid / rigid stranded / flexible)		Cross-sectional area (mm ²)		Verdict	
TABLE: test with apparatus shown in Figure 13							
Cross-sectional area per Table 10 (mm ²)	Type of conductor (solid / rigid stranded / flexible per Table 10)	Diameter of bushing hole per Table 10 (mm)	Height H per Table 10 (mm)	Mass per Table 10 (kg)	Verdict		
supplementary information:							

12.3.12	TABLE: deflection test (principle of test apparatus shown in Figure 14a)						N/A
	Test carried out connecting rigid solid copper conductors:						
	test current (A) (equal rated current)						—
	required voltage drop (mV)				≤ 25 mV		—

IEC 60884-1 - TABLES							
Clause	Requirement + Test			Result - Remark			Verdict
Type of conductor	Smallest			Largest			Verdict
cross-sectional area per Table 12 (mm ²)							
force per Table 13 (N)							
Screwless-type terminal number	1	2	3	1	2	3	
starting point (X = deflection original point)	X	X+10°	X+20°	X	X+10°	X+20°	
voltage drop 1 st deflection (mV)							
voltage drop 2 nd deflection (mV)							
voltage drop 3 rd deflection (mV)							
voltage drop 4 th deflection (mV)							
voltage drop 5 th deflection (mV)							
voltage drop 6 th deflection (mV)							
voltage drop 7 th deflection (mV)							
voltage drop 8 th deflection (mV)							
voltage drop 9 th deflection (mV)							
voltage drop 10 th deflection (mV)							
voltage drop 11 th deflection (mV)							
voltage drop 12 th deflection (mV)							
supplementary information:							

14.22	TABLE: Components					P
Object / part No.	Manufacturer/ trademark	Type / model	Technical data	Standard	Mark(s) of conformity ¹⁾	
Base	Sabic	Lexan 223R	-	IEC 60884-1	Tested with the unit	
Front cover plate	Sabic	Lexan 223R	-	IEC 60884-1	Tested with the unit	
Contacts	-	CuZn37 R550	-	IEC 60884-1	Tested with the unit	
Earthing contacts	-	CuZn37 R550	-	IEC 60884-1	Tested with the unit	

Supplementary information:
¹⁾ Provided evidence ensures the agreed level of compliance. See OD-CB2039.

17.2	TABLE: insulation resistance		P
	Rated voltage (V)	250 V	-

IEC 60884-1 - TABLES			
Clause	Requirement + Test	Result - Remark	Verdict
Item per 17.2.1 17.2.2 17.2.3	Test voltage applied between:	Measured (MΩ)	Required (MΩ)
a	Poles connected together and body (plug engaged)	> 100 MΩ	> 5 MΩ
b	Each pole and others connected together (plug engaged)	> 100 MΩ	> 5 MΩ
supplementary information:			

17.3	TABLE: electric strength			P
	Rated voltage (V)	250 V		—
Item per 17.2.1 17.2.2 17.2.3	Test voltage applied between:	Test voltage (V)	Flashover / breakdown (Yes/No)	
a	Poles connected together and body (plug engaged)	2000 V	No	
b	Each pole and others connected together (plug engaged)	2000 V	No	
supplementary information:				

19.2	TABLE: temperature rise test for plugs and socket-outlets							P
	rated current of accessory (A)		16 A					—
	portable accessory (non-rewirable / rewirable)		Rewirable					
	type of accessory (portable / fixed)		fixed					—
	nominal cross-sectional area per Table 16 (mm ²) ...		2,5 mm ²					—
	type of conductors (rigid solid / rigid stranded / flexible)		Rigid solid					—
	nominal diameter of thread (mm); torque 2/3 of that specified in 12.2.8 (Nm)		3,4 mm; 0,53 Nm					—
specimen	type of flexible cable ⁽¹⁾	number of conductors and nominal cross- sectional area (mm ²) ⁽¹⁾	test circuit (L-L / L-N / L-E)	test current (Table 18) for 60+5/0 min (A)	measured ΔT (K)	allowed ΔT (K)	ΔT of external parts of insulating material (25.3)(K)	
A, B, C	/	/	L-N	22	26	45	3	
A, B, C	/	/	L-E	22	39	45	2	
supplementary information: Only max measurement stated								
⁽¹⁾ Non-rewirable accessories								

IEC 60884-1 - TABLES			
Clause	Requirement + Test	Result - Remark	Verdict

19.3	TABLE: temperature rise test for fixed socket-outlets of a socket-outlet and fused plug system								N/A
	rated current of accessory (A)								—
	portable accessory (non-rewirable / rewirable)								—
	nominal cross-sectional area per table 16 (mm ²)								—
	type of conductors (rigid solid / rigid stranded / flexible) :								—
	nominal diameter of thread (mm); torque 2/3 of that specified in 12.2.8 (Nm)								—
	Test a) single socket-outlet								
specimen	type of flexible cable (1)	no. of conductors / nom. cross-sectional area (mm ²) (1)	test circuit (L-L / L-N / L-E)	70% of test current (table 18) for 60+5/0 min (socket-outlet) (A)	30% of test current (table 18) for 60+5/0 min (looped) (A)	test current (table 18) for 60+5/0 min (supply cable) (A)	measured ΔT (K)	allowed ΔT (K)	ΔT of external parts of insulating material (25.3)(K)
supplementary information:									
(1) Non-rewirable accessories									
	Test b) multiple socket-outlet								N/A
specimen	type of flexible cable (1)	no. of conductors / nom. cross-sectional area (mm ²) (1)	test circuit (L-L / L-N / L-E)	70% of test current (table 18) for 60+5/0 min (1 st socket-outlet) (A)	30% of test current (table 18) for 60+5/0 min (2 nd socket-outlet) (A)	test current (table 18) for 60+5/0 min (supply cable) (A)	measured ΔT (K)	allowed ΔT (K)	ΔT of external parts of insulating material (25.3)(K)
supplementary information:									
(1) Non-rewirable accessories									

19.4	TABLE: temperature rise test for accessories with incorporated components not covered by other parts of IEC 60884 series								N/A
	rated current of accessory (A)								—
	portable accessory (non-rewirable / rewirable)								—
	type of accessory (portable / fixed).....								—
	nominal cross-sectional area per Table 16 (mm ²) ... :								—
	type of conductors (rigid solid - stranded / flexible).... :								—

IEC 60884-1 - TABLES			
Clause	Requirement + Test	Result - Remark	Verdict

		nominal diameter of thread (mm); torque 2/3 of that specified in 12.2.8 (Nm):					—	
		Test for socket-outlets and rewirable plugs with incorporated components						
specimen	type of flexible cable ⁽¹⁾	number of conductors and nominal cross-sectional area (mm ²) ⁽¹⁾	test circuit (L-L / L-N / L-E)	Test 1 test current, Table 18, Clause 19 (A)	Test 2 (A)	measured ΔT (K)	allowed ΔT (K)	ΔT of external parts (25.3)(K) ⁽²⁾

Supplementary information:

Test 1:

Incorporated components connected in series have been short circuited

Incorporated components connected in parallel have been disconnected

Test 2, incorporated components in series:

Test current equal to rated current of accessory or rated current of component

Test 2, incorporated components in parallel:

Test current equal to rated current of accessory or with the component working as in normal use

⁽¹⁾ Non-rewirable accessories ; ⁽²⁾ Metal parts 30 K ; non-metallic parts 40 K

		Test for non-rewirable plugs with incorporated components						N/A
specimen	type of flexible cable (1)	number of conductors and nominal cross-sectional area (mm ²) (1)	test circuit (L-L / L-N / L-E)	Test 3 (A)	Test 4 (A)	measured ΔT (K)	allowed ΔT (K)	ΔT of external parts (25.3)(K) ⁽²⁾

Supplementary information:

Test 3): test current for the combination plug / cable as indicated in Table 18, for Clause 19.

Incorporated components connected in series have been short circuited

Incorporated components connected in parallel have been disconnected

Test 4), incorporated components connected in series:

test current for the combination plug / cable as indicated in Table 18, for Clause 21, or

rated current of the component(s); (the lower).

Test 4), incorporated components connected in parallel:

the test current for the combination plug / cable as indicated in Table 18, for Clause 21, with the incorporated component working as in normal use.

⁽¹⁾ Non-rewirable accessories; ⁽²⁾ Metal parts 30 K ; non-metallic parts 40 K

IEC 60884-1 - TABLES							
Clause	Requirement + Test	Result - Remark					Verdict
19.5.1.2	TABLE: temperature rise test for accessories with crimped connections						N/A
	rated current of accessory (A)						—
	type of accessory (portable / fixed)						—
	nominal cross-sectional area (mm ²)						—
	test current (Table 18) for time sufficient to reach steady-state value or 4 h (A)						—
	AC / DC test current per Table 17 per each cycle passed for 45 ^{+1/0} min (A)						—
	The accessory shall then be left without current for 15 min (0, -1 min).					—	
Crimped connections number	1	2	3	4	5	6	Verdict
measurement at the 50 th cycle (K)							—
measurement at the 100 th cycle (K)							—
measurement at the 150 th cycle (K)							—
measurement at the 200 th cycle (K)							—
measurement at the 250 th cycle (K)							—
a) temperature rise measurement (max 45 K)							
b) temperature rise measurement average at the 250 th cycle (max 35 K)							
c) linear trend-line							—
at the 50 th cycle (K)							—
at the 250 th cycle (K)							—
The value given by each trend-line at the 250 th cycle does not exceed the value given on the trend-line at the 50 th cycle by more than 5 K (ΔK)							
When c) is not fulfilled the test is extended to 500 cycles (additional conditions d) - e)							
Crimped connections number	1	2	3	4	5	6	Verdict
measurement at the 300 th cycle (K)							—
measurement at the 350 th cycle (K)							—
measurement at the 400 th cycle (K)							—
measurement at the 450 th cycle (K)							—
measurement at the 500 th cycle (K)							—

IEC 60884-1 - TABLES							
Clause	Requirement + Test					Result - Remark	Verdict
d)	temperature measurement rise average at the 500 th cycle (max 35 K)						
e)	linear trend-line						—
	at the 250 th cycle (K)						—
	at the 500 th cycle (K)						—
	The value given by each trend-line at the 500 th cycle does not exceed the value given on the trend-line at the 250 th cycle by more than 10 K (ΔK)						

19.5.2	TABLE: temperature rise test for fixed socket-outlets incorporating pilot-lights				N/A
	rated current of accessory (A)				—
	nominal cross-sectional area per Table 16 (mm ²) ...				—
	type of conductors (rigid solid / rigid stranded / flexible)				—
	nominal diameter of thread (mm); torque 2/3 of that specified in 12.2.8 (Nm)				—
specimen	pilot light supplied at rated voltage	fixed socket-outlet loaded at rated current	external surface of the fixed socket-outlets		allowed ΔT (K)
			metallic material	non-metallic material	
supplementary information:					

20	TABLE: breaking capacity		P
	rating of accessory (A/V)	16 A; 250 V	—
	Type of accessory (portable / fixed)	Fixed	
	type of flexible cable (non-rewirable accessories) ..	/	—
	number of conductors and nominal cross-sectional area (mm ²) (non-rewirable accessories)	/	—
	nominal cross-sectional area per Table 16 (mm ²) ...	2,5 mm ²	—
	type of conductors (rigid solid / rigid stranded / flexible)	Rigid solid	—
	nominal diameter of thread (mm); torque 2/3 of that specified in 12.2.8 (Nm)	3,4 mm; 0,53 Nm	—

IEC 60884-1 - TABLES									
Clause	Requirement + Test					Result - Remark			Verdict
	rate of operation (strokes per minute)					30			—
specimen	test plug (for each type and current rating of socket-outlet)		test voltage (1,1 Vn) (V)	test current (1,25 In) cos φ 0,6 (A)	number of strokes (plugs only)	number of strokes, with shutters – with current ⁽¹⁾	number of strokes, without shutters – with current ⁽²⁾	remarks	
	pin dimensions (mm)	pin spacing (mm)							
A,B,C	4,86 mm	19,0 mm	275 V	20 A	/	/	200	/	P
supplementary information:									
⁽¹⁾ starting point 1 or 3 of Figure 24									
⁽²⁾ starting point 2 of Figure 24									

21	TABLE: normal operation								P
	rating of accessory (A/V)					16 A; 250 V			—
	Type of accessory (portable / fixed).....					Fixed			
	type of flexible cable (non-rewirable accessories) ..					/			—
	number of conductors and nominal cross-sectional area (mm ²) (non-rewirable accessories)					/			—
	nominal cross-sectional area per Table 16 (mm ²) ...					2,5 mm ²			—
	type of conductors (rigid solid / rigid stranded / flexible)					Rigid solid			—
	nominal diameter of thread (mm); torque 2/3 of that specified in 12.2.8 (Nm).....					3,4 mm; 0,53 Nm			—
	rate of operation (strokes per minute)					30			—
specimen	test plug (for each type and current rating of socket-outlet)		test voltage (Vn) (V)	test current (Table 18), cos φ 0,8 (A)	number of strokes (plugs only)	number of strokes, with shutters – with current ⁽¹⁾	number of strokes, without shutters – with current ⁽²⁾	number of strokes, with shutters – without current ⁽³⁾	
	pin dimensions (mm)	pin spacing (mm)							
A, B, C	4,86mm	19,0 mm	250	16	/	/	10000	/	P
	TABLE: test for shuttered socket-outlets								N/A
specimen	Gauge of Figure 7, applied with a force of 20 N, for approximately 5 s, successively in three directions				Steel gauge of Figure 8, applied with a force of 1 N for approximately 5 s, in three directions				
19	TABLE: temperature rise test								P

IEC 60884-1 - TABLES						
Clause	Requirement + Test			Result - Remark	Verdict	
specimen	test circuit (L-L/L-N/L-E)	test current (Table 18 for clause 21) for 60+5/0 min (A)		measured dT (K)	allowed dT (K)	
A, B, C	L-N	16 A		27	45	P
A, B, C	L-E	16 A		33	45	P
17.3	TABLE: electric strength					
specimen	item per 17.2.1 17.2.2 17.2.3	test voltage applied between:		test voltage (V)	flashover / breakdown (Yes/No)	
A, B, C	a	Poles connected together and body (plug engaged)		1500 V	No	
A, B, C	b	Each pole and others connected together (plug engaged)		1500 V	No	
supplementary information: *Only max. measurements stated for temperature rise test						
(1) starting point 1 or 3 of Figure 24						
(2) starting point 2 of Figure 24						
(3) starting point 1 or 2 of Figure 24						

22	TABLE: force necessary to withdraw the plug					P
22.1	Rated current (A)			16 A	—	
	Number of poles			3	—	
22.2	Verification of the maximum withdrawal force					
specimen	22.2.1 socket-outlets (multi-pin gauge)		22.2.2 plugs with individual resilient earthing contact assemblies (single-pin gauge)			
	maximum withdrawal force (N)	the test plug did not remain in the socket-outlet	maximum withdrawal force (N)	the test pin gauge did not remain in the individual resilient earthing contact assembly		
A, B, C	54	Y	/	/		P
22.3	Verification of the minimum withdrawal force					P
specimen	socket-outlets (single-pin gauge)		plugs with individual earthing contact assemblies (single-pin gauge)			
	minimum withdrawal force (N)	the test pin gauge did not fall from each individual contact- assembly within 30 s	minimum withdrawal force (N)	the test pin gauge did not fall from each individual earthing contact-assembly within 30 s		
A, B, C	2	Y	/	/		P
supplementary information:						

IEC 60884-1 - TABLES						
Clause	Requirement + Test			Result - Remark		Verdict
23.2	TABLE: pull and torque test					N/A
	rated current (A) / rated voltage (V) A / ... V		—
	type of accessory (non-rewirable / rewirable)					—
	smallest/largest cross-sectional area per Table 20 (mm ²) (rewirable accessories)					—
	nominal diameter of thread (mm); torque 2/3 per Table 7 (Nm) (rewirable accessories)					—
specimen	type of flexible cable	number of conductors and nominal cross-sectional area (mm ²)	pull (100 times) (N) for 1 s without jerks	torque (1 min) as specified in Table 21 (Nm)	displacement (mm)	
supplementary information:						

23.4	TABLE: flexing test				N/A	
	rated current (A) / rated voltage (V) A / ... V		—
specimen	type of flexible cable	number of conductors and nominal cross-sectional area (mm ²)	test current (A)	mass (N)		
supplementary information:						

24.2	TABLE: impact test			
Part of enclosure tested per Table 21 (A, B, C, D)	Blows per part	Height of fall (mm) (Table 23)	Comments	
A	5	80 mm	No damage	
supplementary information: Same results on all samples				

IEC 60884-1 - TABLES			
Clause	Requirement + Test	Result - Remark	Verdict
25.3	TABLE: ball pressure test of insulating materials		P
	allowed impression diameter (mm) :	≤ 2 mm	—
part under test (*)		test temperature (°C)	impression diameter (mm)
Base (Lexan 223R)		125°C	< 1,0 mm
Front cover plate (Lexan 223R)		125°C	< 1,0 mm
(*) supplementary information: <input type="checkbox"/> An aged sample, same material has been used <input checked="" type="checkbox"/> Test carried out on a cut piece at least 2 mm thick <input checked="" type="checkbox"/> Four layers are used; total thickness not less than 2,5 mm			

25.4	TABLE: ball pressure test of insulating materials		N/A
	allowed impression diameter (mm) :	≤ 2 mm	—
part under test		test temperature (°C) ⁽¹⁾	impression diameter (mm)
supplementary information: ⁽¹⁾ (70 ± 2) °C / (40 ± 2) °C + highest temperature rise determined during the test of clause 19			

26.1	TABLE: threaded part torque test				P
threaded part identification	diameter of thread (mm) (Table 7)	column number (1, 2 or 3) (Table 7)	applied torque (Nm) (Table 7)	times (5/10)	no damage
Terminal screws (L,N)	3,4 mm	2	0,8 Nm	5	P
Terminal screw (E)	3,4 mm	2	0,8 Nm	5	P
Cover plate screws	2,8 mm	2	0,4 Nm	5	P
supplementary information:					

IEC 60884-1 - TABLES							
Clause	Requirement + Test			Result - Remark			Verdict
27.1	TABLE: creepage distances, clearances and distances through sealing compound						P
	rated voltage (V)			250 V			—
item per Table 26	creepage distance dcr, clearance cl and distance through sealing compound dtsc at/of:	required cl (mm)	cl (mm)	required dcr (mm)	dcr (mm)	required dtsc (mm)	dtsc (mm)
1, 6	Between live parts of different polarity	≥ 3	> 10,0	≥ 3	> 10,0	/	/
2, 7	Between live parts and accessible surface of insulating material	≥ 3	8,1	≥ 3	8,1	/	/
2, 7	Between live parts and parts of earthing circuit	≥ 3	7,3	≥ 3	7,3	/	/
supplementary information:							

28.1.2	TABLE: glow-wire test					P
part under test	material designation	test temperature (°C)	visible flame and sustained glowing (Y/N)	flame and glowing extinction time	ignition of the tissue paper (Y/N)	
Base	Lexan 223R	850°C	Y	25/31	N	
Front cover plate	Lexan 223R	650°C	N	/*	N	
supplementary information: *No fire. No drops.						

IEC 60884-1 - Annex C (normative)
Switches incorporated in portable socket-outlets

Clause	Requirement + Test	Result - Remark	Verdict
	Switches incorporated in portable socket-outlets comply with the relevant part of the IEC 60669 series or IEC 61058 series		N/A
	Rating of the switch is not lower than the lowest rating of the socket-outlet or the incorporated overcurrent protective device		N/A
	Switches marked with OFF state: - normal gap construction - disconnect all the live poles		N/A
	Switches complying with IEC 61058-1 have the following minimum classification:		N/A
	- Pollution degree 2		N/A
	- Rated impulse withstand voltage 2500 V		N/A
	- Level of resistance to fire with test according to glow wire temperature 750 °C		N/A
	- 10000 operating cycles		N/A

IEC 60884-1 - Annex D (normative)

**Requirements for plugs and fixed or portable socket-outlets
intended to be used with AWG cables**

NOTE The following modifications to the International Standard IEC 60884-1:2022 are applicable for plugs and fixed or portable socket-outlets intended to be used with AWG cables.

The clause numbers in this annex refer to the clause numbers in the main body text of document IEC 60884-1:2022

1	SCOPE		N/A
	Clause 1 applied except:		—
	<i>Replacement of the first paragraph</i>		—
	This part of IEC 60884 applies to:		—
	- plugs - fixed or portable socket-outlets for AC only		N/A
	- with or without earthing contact		N/A
	- rated voltage greater than 50 V, but not exceeding 250 V		N/A
	- rated current not exceeding 30 A		N/A
	intended for household and similar purposes, either indoors or outdoors, to be used with AWG cables		N/A
	<i>Replaced the second paragraph</i>		—
	Rated current limited to 15 A maximum for fixed socket-outlets provided with screwless-type terminals		N/A
2	NORMATIVE REFERENCES		N/A
	Clause 2 applied		—
3	TERMS AND DEFINITIONS		N/A
	Clause 3 applied		—
4	GENERAL REQUIREMENTS		N/A
	Clause 4 applied		—
5	GENERAL REMARKS ON TESTS		N/A
	Clause 5 applied		—
6	RATINGS		N/A
	Clause 6 applied except:		—
	<i>Replacement of Table 2 - Preferred combinations of type and ratings</i>		—
	Type		N/A
	Ratings (A / V)		N/A
7	CLASSIFICATION		N/A
	Clause 7 applied		—

IEC 60884-1 - Annex D (normative)			
Clause	Requirement + Test	Result - Remark	Verdict
8	MARKING		N/A
8.1	Addition:		—
	- size of AWG conductor(s) marked on the socket-outlet	AWG ...	N/A
8.2	Addition:		—
	Non-removable terminal screws used to indicate conductor connections: white (silver) colour for the neutral conductor green colour for earthing conductor		N/A
9	CHECKING OF DIMENSIONS		N/A
9.1	Clause 9 applied		—
10	PROTECTION AGAINST ELECTRIC SHOCK		N/A
	Clause 10 applied except:		—
10.2	<i>Replacement of the fourth paragraph</i>		—
	Test carried out on the specimen mounted as for normal use, fitted with conductors of the smallest AWG size specified in the new Table 4		N/A
	Repeated test with conductors largest AWG size		N/A
11	PROVISION FOR EARTHING		N/A
11.1	Clause 11 applied		—
12	TERMINALS AND TERMINATIONS		N/A
	Clause 12 applied except:		—
	<i>Replacement of Table 4 - Relationship between rated current / AWG size</i>		—
	- Fixed type accessories - rigid (solid or stranded) copper conductors	<input type="checkbox"/>	N/A
	- Portable type accessories - flexible copper conductors	<input type="checkbox"/>	N/A
	- Current (A) A	N/A
	- AWG size	AWG ...	N/A
	- Diameter of the largest conductor (mm) mm	N/A
	<i>Replacement of Figure 9 to Figure 12 and associated keys and Tables</i>		—
12.2.1	<i>Replacement of the last two paragraphs by:</i>		—
	- Conductor space is at least that indicated in column 3 or 5 of the new Table 4		N/A
	Checked by inspection, by measurement, by fitting the smallest and largest AWG sizes specified	by...	N/A

IEC 60884-1 - Annex D (normative)			
Clause	Requirement + Test	Result - Remark	Verdict
12.2.5	<i>Replacement of the third paragraph</i>		—
	Terminal placed in the test apparatus according to Figure 13		N/A
	- fitted with rigid, solid, stranded and/or flexible conductor(s), according to the new Table 4		N/A
	- first the smallest, then the largest AWG size		N/A
	- clamping screw(s) or nut(s) tightened according to Table 7	See appended Table D.12.2.5	N/A
D.12.2.6	<i>Replacement of the fourth paragraph</i>		—
	Terminals fitted with:		—
	- rigid solid or stranded conductors for fixed socket-outlets		N/A
	- flexible conductors for plugs and portable socket-outlets		N/A
	- used conductors of the smallest / largest AWG size specified in the new Table 4		N/A
	- terminal screws tightened with 2/3 of the torque shown in Table 7	See appended Table D.12.2.6	N/A
	<i>Replacement of Table 5 - Screw terminals: pull values</i>		—
	Nominal cross-sectional area / AWG size	AWG ...	N/A
	Pull (N) N	N/A
12.2.7	<i>Replacement of the third paragraph</i>		—
	Terminals fitted with conductors having the largest AWG size specified in the new Table 4	See appended table D.12.2.7	N/A
	<i>Replacement of Table 6 - Composition of conductors</i>		—
	AWG size	AWG ...	N/A
	No. of wires and nom. diameter, flexible conductor :		N/A
	No. of wires and nom. diameter, rigid solid conductor		N/A
	No. of wires and nom. diameter, rigid stranded conductor		N/A
12.2.8	<i>Replacement of the third paragraph</i>		—
	A rigid solid copper conductor of the AWG size specified in the new Table 4 placed in the terminal		N/A
	<i>Replace the seventh paragraph</i>		—
	Screws/nuts tightened/loosened five times; torque applied as shown in Table 7		N/A

IEC 60884-1 - Annex D (normative)			
Clause	Requirement + Test	Result - Remark	Verdict
12.2.9	Deleted note		—
12.2.11	Subclause not applicable		—
12.3.2	<i>Replacement Table 8 - Relations between rated current and connectable AWG size for screwless terminals</i>		—
	- rated current (A)	15 A	—
	- AWG size	AWG 14	—
	- diameter of rigid conductor (mm)	1,63 mm	—
	<i>Replacement of the last paragraph</i>		—
	Checked by inspection and by fitting the specified conductors of the smallest and largest AWG sizes as marked on the device		N/A
12.3.10	<i>Replacement of the third paragraph</i>		—
	Test carried out with rigid solid copper conductors, - first conductors having the largest AWG size, - then conductors having the smallest AWG size specified in the new Table 8	See appended table D.12.3.10	N/A
	<i>Replacement of the seventh paragraph</i>		—
	Test repeated with rigid stranded copper conductors having AWG sizes specified in 12.3.2 (connected and disconnected only once)	See appended table D.12.3.10	N/A
	<i>Replacement of Table 10 - Mechanical load test for copper conductors: values for flexing</i>		—
	- AWG size.....	AWG ...	N/A
	- Diameter of bushing hole (mm).....	... mm	N/A
	- Height H (mm) mm	N/A
	Mass for conductor (kg).....	... kg	N/A
12.3.11	<i>Replacement of the first paragraph of item a)</i>		—
	a) Test carried out loading the screwless-type terminals for 1 h with an alternating current as specified in Table 11 and connecting rigid solid conductors 1 m long	See appended table D.12.3.11	N/A
	<i>Replacement of Table 11 - Verification of electrical and thermal stresses for screwless-type terminals</i>		—
	- rated current (A)	15 A	—
	- test current (A).....	21 A	—
	- AWG size	AWG 14	—
12.3.12	<i>Replacement of the eighth paragraph after the NOTE</i>		—

IEC 60884-1 - Annex D (normative)			
Clause	Requirement + Test	Result - Remark	Verdict
	A clamping unit fitted with a rigid solid copper conductor, AWG size 16, and submitted to a first test sequence	See appended table D.12.3.12	N/A
	Submitted to a second test sequence using a conductor AWG size 14, unless the first test sequence has failed	See appended table D.12.3.12	N/A
	Deleted Table 12		—
	<i>Replacement of Table 13 - Deflection test forces</i>		—
	- AWG size of the test conductor..... :	AWG ...	N/A
	- Deflecting force (N) N	N/A
13	CONSTRUCTION OF FIXED SOCKET-OUTLETS		N/A
	Clause 13 applied, except		—
13.4	<i>Replacement of the second paragraph after NOTE 2</i>		—
	Checked by inspection and by installation test with conductors of the largest AWG size (new Table 4)		N/A
13.4	<i>Replacement of the last paragraph</i>		—
	Checked by inspection and by installation test with conductors of the largest AWG size (new Table 4)		N/A
13.9	<i>Replacement of the third paragraph</i>		—
	Checked by inspection and by installation test with conductors of the smallest AWG size (new Table 15)		N/A
13.14	Second paragraph, replacement of "16 A" by "20 A"		—
13.15	<i>Replacement of Table 15 - External cable limits for surface-type socket-outlets</i>		—
	- rated current (A)		N/A
	- AWG size	AWG ...	N/A
	- Number of conductors		N/A
	- Minimum dimensions (mm)		N/A
	- Maximum dimensions (mm)		N/A
14	CONSTRUCTION OF PLUGS AND PORTABLE SOCKET-OUTLETS		N/A
	Clause 14 applied, except		—
14.9.2	<i>Replacement of the first paragraph</i>		—

IEC 60884-1 - Annex D (normative)			
Clause	Requirement + Test	Result - Remark	Verdict
	A 6 mm length of insulation removed from the end of a flexible conductor; minimum required AWG size specified in the new Table 4. One wire of the flexible conductor left free, and the remaining wires fully inserted into and clamped in the terminal as for normal use.		N/A
14.9.3	<i>Replacement of the first paragraph</i>		—
	A length of insulation equivalent to the maximum designed stripping length declared by the manufacturer, plus 2 mm is removed from the end of a flexible conductor having the AWG size as fitted. One wire of the flexible conductor is left free in the worst position whilst the remaining wires are terminated in a manner as used in the construction of the accessory.		N/A
14.14	Replacement of the second paragraph		—
	Checked by inspection after fitting conductors of the largest AWG sizes specified in Table 4		N/A
15	INTERLOCKED SOCKET-OUTLETS		N/A
	Clause 15 applied		—
16	RESISTANCE TO AGEING, PROTECTION PROVIDED BY ENCLOSURES, AND RESISTANCE TO HUMIDITY		N/A
	Clause 16 applied, except		—
16.2.3	<i>Replacement of the first paragraph, after Fig. 18</i>		—
	Surface type socket-outlets: mounted in a vertical position and fitted with cables or conduits or both in accordance with the manufacturer's instructions. Cables conductors of the largest and smallest AWG size (new Table 4)		N/A
	<i>Replacement of the first paragraph, after Fig. 19</i>		—
	Portable socket-outlets: tested on a flat, horizontal surface in a position, such that there is no strain on the flexible cable and fitted with flexible cables (new Table 20) having conductors of the largest and smallest AWG size (new Table 4).		N/A
17	INSULATION RESISTANCE AND ELECTRIC STRENGTH		N/A
	Clause 17 applied		—
18	OPERATION OF EARTHING CONTACTS		N/A
	Clause 18 applied		—
19	TEMPERATURE RISE		N/A
	Clause 19 applied, except		—

IEC 60884-1 - Annex D (normative)			
Clause	Requirement + Test	Result - Remark	Verdict
	<i>Replacement of Table 16 - Temperature rise test: AWG sizes of copper conductors</i>		N/A
	Rated current (A) A See appended tables D.19	N/A
	Nominal cross-sectional area of flexible conductors for portable accessories	AWG ... See appended tables D.19	N/A
	Nominal cross-sectional area of rigid (solid or stranded) conductors for fixed accessories	AWG ... See appended tables D.19	N/A
	<i>Table 17 - Test current for cycling tests on accessories with crimped connection</i>		—
	<i>Replacement "16" by "20" in columns 3, 4; replaced "32" by "30" in column 6</i>		—
20	BREAKING CAPACITY		N/A
	Clause 20 applied, except		—
	<i>Replacement of "16 A" by "20 A" in three locations in the two dashed lists</i>		—
	See appended table D.20		—
21	NORMAL OPERATION		N/A
	Clause 21 applied, except		—
	<i>Replacement of "16 A" by "20 A" in four locations: in the first and second dashed lists and in the paragraph directly following Figure 24</i>		—
	See appended table D.21		—
23	FLEXIBLE CABLES AND THEIR CONNECTION		N/A
	Clause 23 applied, except		—
23.2	Cord anchorage		—
	<i>Replacement of the third paragraph</i>		—
	Rewirable accessories: - tested with a cable having the smallest AWG size - tested with a cable having the largest AWG size as shown in new Table 20	See appended Table D.23.2	N/A
	<i>Replacement of Table 20 - External dimensions of flexible cables accommodated by cord anchorages</i>		—
	- conductors introduced into the terminals		N/A
	- terminal screws tightened sufficiently to prevent the position of the conductors from easily changing		N/A
	- cord anchorage used in the normal way: clamping screws tightened with torque two-thirds of that specified in Table 7		N/A
	- with specimen reassembled, the component parts are fit snugly- with specimen reassembled, the component parts are fit snugly		N/A

IEC 60884-1 - Annex D (normative)			
Clause	Requirement + Test	Result - Remark	Verdict
	- it is not possible to push the flexible cable appreciably into the sample		N/A
	- the axis of the flexible cable is vertical		N/A
	Test (<i>replacement of the fifth paragraph after Table 20</i>):		N/A
	Flexible cable then subjected 100 times to a pull of:		N/A
	<ul style="list-style-type: none"> • 60 N if the rated current is 15 A • 100 N if the rated current is 20 A or 30 A 	See appended Table D.23.2	N/A
	Pulls applied each time for 1 s without jerks		N/A
	Pulls exert simultaneously on all parts of the cable		N/A
	Immediately afterwards, the flexible cable is subjected for 1 min to a torque as specified in new Table 21 (<i>replaced</i>)	See appended Table D.23.2	N/A
	After the test:		—
	Displacement ≤ 2 mm	See appended Table D.23.2	N/A
	Rewirable accessories: end of conductors have not moved noticeably in the terminals		N/A
	Non-rewirable accessories: no break in the electrical connections		N/A
	Measurements of the longitudinal displacement made at a distance of 20 mm from the end of the specimen, or the flexible cable guard, while the flexible cable is subjected to the pull		N/A
	In addition, for rewirable accessories having a rated current up to and including 30 A: manual test to check that they are suitable for fitting with the appropriate cable, as shown in the new Table 22 (<i>replaced</i>)		N/A
	- rating of accessory (A) :	... A	N/A
	- number of poles..... :		N/A
	- types of flexible cable (cable references)..... :		N/A
	- number of conductors and AWG size :	AWG ...	N/A
	- maximum dimensions for flexible cables :		N/A
23.3	<i>Replacement of the first paragraph</i>		—
	Non-rewirable plugs / non-rewirable portable socket-outlets are provided with a flexible cable having conductors with AWG sizes in relation to the rating of the accessory as given in new Table 18		N/A
	<i>Replacement of Table 18</i> <i>Relationship between rating of accessories, AWG size of test conductors and test currents for the tests of Clauses 19 - 21</i>		—

IEC 60884-1 - Annex D (normative)			
Clause	Requirement + Test	Result - Remark	Verdict
	- Rating of accessory..... :		N/A
	- Rewirable fixed accessory		N/A
	- test current clause 19..... :		N/A
	- test current clause 21..... :		N/A
	- Rewirable portable accessory		N/A
	- test current clause 19..... :		N/A
	- test current clause 21..... :		N/A
	- Non-rewirable portable socket-outlet		N/A
	- AWG size..... :		N/A
	- test current clause 19..... :		N/A
	- test current clause 21..... :		N/A
	- Non-rewirable plugs		N/A
	- AWG size..... :		N/A
	- test current clause 19..... :		N/A
	- test current clause 21..... :		N/A
23.4	Replacement of the fourth and fifth paragraphs after Figure 28 by:		—
	Flexible cable: force applied, 20 N	See appended Table D.23.4	N/A
	Current passed through the conductors: 15 A		N/A
24	MECHANICAL STRENGTH		N/A
	Clause 24 applied, except:		—
24.2	Replacement of the first paragraph by:		—
	Rewirable portable accessories fitted with the flexible cable specified in 23.2 having the smallest AWG size specified in new Table 4 and a free length of approximately 100 mm measured from the outer end of the guard		N/A
24.10	Test for multiple portable socket-outlets		—
	<i>Replacement of the first paragraph by:</i>		—
	Rewirable multiple portable socket-outlets fitted with the lightest type of flexible cable of the smallest AWG size specified in new Table 4		N/A
25	RESISTANCE TO HEAT		N/A
	Clause 25 applied		—
26	SCREWS, CURRENT-CARRYING PARTS AND CONNECTIONS		N/A
	Clause 26 applied		—

IEC 60884-1 - Annex D (normative)			
Clause	Requirement + Test	Result - Remark	Verdict
27	CREEPAGE DISTANCES, CLEARANCES AND DISTANCES THROUGH SEALING COMPOUND		N/A
	Clause 27 applied, except:		—
27.1	Replacement of second paragraph, after Table 26		N/A
	Rewirable accessories: measurements made with conductors of the largest AWG size specified in Table 4 and also without conductors	See appended Table D.27.1	N/A
28	RESISTANCE OF INSULATING MATERIAL TO ABNORMAL HEAT, TO FIRE AND TO TRACKING		N/A
	Clause 28 applied		—
29	RESISTANCE TO RUSTING		N/A
	Clause 29 applied		—
30	ADDITIONAL TESTS ON PINS PROVIDED WITH INSULATING SLEEVES		N/A
	Clause 30 applied		—
31	EMC REQUIREMENTS		N/A
	Clause 31 applied		—
32	ELECTROMAGNETIC FIELDS (EMF) REQUIREMENTS		N/A
	Clause 32 applied		—

IEC 60884-1 - Annex D (normative) - TABLES				
Clause	Requirement + Test		Result - Remark	Verdict
D.12.2.5	TABLE: test with apparatus shown in Figure 13 (screw-type terminals) (*)			N/A
	rated current (A)			—
	type of copper conductors		<input type="checkbox"/> rigid solid <input type="checkbox"/> rigid stranded <input type="checkbox"/> flexible	—
	smallest / largest AWG size (new Table 4)			—
	nom. diameter of thread (mm); torque Table 7 (Nm) :			—
AWG size	Diameter of bushing hole per new Table 10 (mm)	Height H per new Table 10 (mm)	Mass (kg) per new Table 10	Verdict
supplementary information: (*) according to new Tables 4; 10				

D.12.2.6	TABLE: pull test (screw-type terminals) (*)			N/A
	rated current (A)			—
	smallest / largest AWG size (new Table 4)			—
	nominal diameter of thread (mm); torque 2/3 per Table 7 (Nm)			—
AWG size	Type of conductors (rigid solid / rigid stranded / flexible)	Pull per new Table 5 applied for 1 min (N)	Verdict	
supplementary information: (*) according to new Tables 4; 5				

D.12.2.7	TABLE: tightening test (screw-type terminals) (*)			N/A
	rated current (A)			—
	nominal diameter of thread (mm); torque 2/3 per Table 7 (Nm)			—
AWG size	Permissible number of conductors ⁽¹⁾	Type of conductors (rigid solid / rigid stranded / flexible)	Number of wires and nominal diameter of wires per the new Table 6	Verdict
supplementary information: (*) according to new Tables 4; 6				
⁽¹⁾ terminals intended for looping-in 2 or 3 conductors				

D.12.3.10	TABLE: mechanical strength test (screwless-type terminals) (*)			N/A
	Rated current (A)		15 A	—

IEC 60884-1 - Annex D (normative) - TABLES						
Clause	Requirement + Test			Result - Remark	Verdict	
	AWG size per new Table 8..... : 14				—	
	Diameter of rigid conductor : 1,63 mm				—	
	Number of connection (after that conductor subjected to a pull of 30 N for 1 min) / disconnection	Type of conductor (solid / rigid stranded)		AWG size	Verdict	
	TABLE: test with apparatus shown in Figure 13				N/A	
	AWG size per new Table 10	Type of conductor (solid / rigid stranded) per new Table 10	Diameter of bushing hole per new Table 10 (mm)	Height H per new Table 10 (mm)	Mass (kg) per new Table 10	Verdict
	supplementary information: (*) according to new Tables 4; 6					

D.12.3.11		TABLE: electrical and thermal strength test (screwless-type terminals) (*)				N/A	
Test a)	Test carried out for 1 h connecting rigid solid conductors						
	Rated current per new Table 11 (A)..... : 15					—	
	Test current per new Table 11 (A) : 21					—	
	AWG size per new Table 11..... : 14					—	
	Screwless-type terminal number	Voltage drop (mV)			Required voltage drop (mV)		
	1				≤ 15		
	2				≤ 15		
	3				≤ 15		
	4				≤ 15		
	5				≤ 15		
Test b)	Temperature cycles test carried out on terminals subjected to Test a):					N/A	
	Test current per new Table 11 (A) : 21 A					—	
	AWG size per new Table 11..... : 14					—	
	Allowed voltage drop (mV) : ≤ 22,5 mV or 2 times 24 th cycle value (mV)					—	
	Screwless-type terminal number	1	2	3	4	5	Verdict
	voltage drop after 24 th cycle						
	voltage drop after 48 th cycle						
	voltage drop after 72 nd cycle						

IEC 60884-1 - Annex D (normative) - TABLES						
Clause	Requirement + Test				Result - Remark	Verdict
	voltage drop after 96 th cycle					
	voltage drop after 120 th cycle					
	voltage drop after 144 th cycle					
	voltage drop after 168 th cycle					
	voltage drop after 192 nd cycle					
D.12.3.10	TABLE: mechanical strength test (screwless-type terminals)					N/A
	Rated current (A) : 15 A					—
	AWG size per new Table 8..... : 14					
	Diameter of rigid conductor 1,63 mm					
Number of connection (after that conductor subjected to a pull of 30 N for 1 min) / disconnection		Type of conductor (solid / rigid stranded)		AWG size		Verdict
TABLE: test with apparatus shown in Figure 13						
AWG size per new Table 10	Type of conductor (solid / rigid stranded) per new Table 10	Diameter of bushing hole per new Table 10 (mm)	Height H per new Table 10 (mm)	Mass (kg) per new Table 10	Verdict	
supplementary information: (*) according to new Table 11						

D.12.3.12	TABLE: deflection test (principle of test apparatus shown in Figure 14a) (*)						N/A
Test carried out connecting rigid solid copper conductors:							
Test current (A) (equal rated current) A		—	
required voltage drop (mV)				≤ 25 mV		—	
Type of conductor	Smallest			Largest			Verdict
AWG size per new Table 12	14			12			
Force per new Table 13 (N)	1,0			1,5			
Screwless-type terminal number	1	2	3	1	2	3	
Starting point (X = deflection original point)	X	X+10°	X+20°	X	X+10°	X+20°	
voltage drop 1 st deflection (mV)							
voltage drop 2 nd deflection (mV)							
voltage drop 3 rd deflection (mV)							

IEC 60884-1 - Annex D (normative) - TABLES							
Clause	Requirement + Test					Result - Remark	Verdict
	voltage drop 4 th deflection (mV)						
	voltage drop 5 th deflection (mV)						
	voltage drop 6 th deflection (mV)						
	voltage drop 7 th deflection (mV)						
	voltage drop 8 th deflection (mV)						
	voltage drop 9 th deflection (mV)						
	voltage drop 10 th deflection (mV)						
	voltage drop 11 th deflection (mV)						
	voltage drop 12 th deflection (mV)						
supplementary information: (*) according to new Tables 12; 13							

D.19.2	TABLE: temperature rise test for plugs and socket-outlets (*)						N/A
	Rated current of accessory (A)						—
	Type of accessory (portable / fixed)						—
	Portable accessory (non-rewirable / rewirable).....						
	AWG size per new Table 16						—
	Type of conductors (rigid solid - stranded / flexible) . :						—
	Nominal diameter of thread (mm); torque 2/3 of that specified in 12.2.8 (Nm).....						—
specimen	AWG size	test circuit (L-L / L-N / L-E)	test current (new Table 18) for 60+5/0 min (A)	measured ΔT (K)	allowed ΔT (K)	ΔT of external parts of insulating material (25.3)(K)	
supplementary information: (*) according to new Tables 16; 18							

D.19.3	TABLE: temperature rise test for fixed socket-outlets of a socket-outlet and fused plug system (*)						N/A
	Rated current of accessory (A)						—
	Type of accessory (portable / fixed)						
	portable accessory (non-rewirable / rewirable).....						
	AWG size per new Table 16						
	Type of conductors (rigid solid - stranded / flexible).....						—
	Nominal diameter of thread (mm); torque 2/3 of that specified in 12.2.8 (Nm).....						—

IEC 60884-1 - Annex D (normative) - TABLES								
Clause	Requirement + Test				Result - Remark			Verdict
	Test a) single socket-outlet							N/A
specimen	AWG size	test circuit (L-L / L-N / L-E)	70% of test current (new Table 18) for 60+5/0 min (socket-outlet) (A)	30% of test current (new Table 18) for 60+5/0 min (looped) (A)	test current (new Table 18) for 60+5/0 min (supply cable) (A)	measured ΔT (K)	allowed ΔT (K)	ΔT of external parts of insulating material (25.3)(K)
supplementary information: (*) according to new Tables 16; 18								
	Test b) multiple socket-outlet							N/A
specimen	AWG size	test circuit (L-L / L-N / L-E)	70% of test current (new Table 16) for 60+5/0 min (1 st socket-outlet) (A)	30% of test current (new Table 16) for 60+5/0 min (2 nd socket-outlet) (A)	test current (new Table 16) for 60+5/0 min (supply cable) (A)	measured ΔT (K)	allowed ΔT (K)	ΔT of external parts of insulating material (25.3)(K)
supplementary information: (*) according to new Table 16								

D.19.4	TABLE: temperature rise test for accessories with incorporated components not covered by other parts of IEC 60884 series (*)							N/A
	Rated current of accessory (A)							—
	Type of accessory (portable / fixed).....							—
	portable accessory (non-rewirable / rewirable)							—
	AWG size per new Table 16							—
	Type of conductors (rigid solid - stranded / flexible).....							—
	Nominal diameter of thread (mm); torque 2/3 of that specified in 12.2.8 (Nm							—
	Test for socket-outlets and rewirable plugs with incorporated components							
specimen	AWG size	test circuit (L-L/L-N/L-E)	Test 1 test current, Table 18, Clause 19 (A)	Test 2 (A)	measured ΔT (K)	allowed ΔT (K)	ΔT of external parts (25.3)(K) ⁽¹⁾	

IEC 60884-1 - Annex D (normative) - TABLES			
Clause	Requirement + Test	Result - Remark	Verdict

Supplementary information: (*) according to new Tables 16; 18

Test 1:

- Incorporated components connected in series have been short circuited
- Incorporated components connected in parallel have been disconnected

Test 2, incorporated components in series:

- Test current equal to rated current of accessory or rated current of component

Test 2, incorporated components in parallel:

- Test current equal to rated current of accessory or with the component working as in normal use

⁽¹⁾ Metal parts 30 K; non-metallic parts 40 K

Test for non-rewirable plugs with incorporated components							N/A
specimen	AWG size	test circuit (L-L/L-N/L-E)	<u>Test 3</u> (A)	<u>Test 4</u> (A)	measured ΔT (K)	allowed ΔT (K)	ΔT of external parts (25.3)(K) ⁽¹⁾

Supplementary information: (*) according to new Tables 16; 18

Test 3): test current for the combination plug / cable as indicated in Table 18, for Clause 19.

- Incorporated components connected in series have been short circuited
- Incorporated components connected in parallel have been disconnected

Test 4), incorporated components connected in series:

- test current for the combination plug / cable as indicated in Table 18, for Clause 21, or
- rated current of the component(s); (the lower).

Test 4), incorporated components connected in parallel:

- the test current for the combination plug / cable as indicated in Table 18, for Clause 21, with the incorporated component working as in normal use.

⁽¹⁾ Metal parts 30 K; non-metallic parts 40 K

IEC 60884-1 - Annex D (normative) - TABLES							
Clause	Requirement + Test	Result - Remark					Verdict
D.19.5.1.2	TABLE: temperature rise test for accessories with crimped connections (*)						N/A
	Rated current of accessory (A)						—
	Type of accessory (portable / fixed)						—
	AWG size per new Table 16						—
	Test current (new Table 18) for time sufficient to reach steady-state value or 4 h (A)						—
	AC / DC test current (new Table 17) per each cycle passed for 45 ^{+1/0} min (A)						—
	The accessory shall then be left without current for 15 min (0, -1 min).						—
Crimped connections number	1	2	3	4	5	6	Verdict
measurement at the 50 th cycle (K)							—
measurement at the 100 th cycle (K)							—
measurement at the 150 th cycle (K)							—
measurement at the 200 th cycle (K)							—
measurement at the 250 th cycle (K)							—
a) temperature rise measurement (max 45 K)							
b) temperature rise measurement average at the 250 th cycle (max 35 K)							
c) linear trend-line							—
at the 50 th cycle (K)							—
at the 250 th cycle (K)							—
The value given by each trend-line at the 250 th cycle does not exceed the value given on the trend-line at the 50 th cycle by more than 5 K (ΔK)							
When c) is not fulfilled the test is extended to 500 cycles (additional conditions d) - e)							
Crimped connections number	1	2	3	4	5	6	Verdict
measurement at the 300 th cycle (K)							—
measurement at the 350 th cycle (K)							—
measurement at the 400 th cycle (K)							—
measurement at the 450 th cycle (K)							—
measurement at the 500 th cycle (K)							—
d) temperature measurement rise average at the 500 th cycle (max 35 K)							

IEC 60884-1 - Annex D (normative) - TABLES							
Clause	Requirement + Test					Result - Remark	Verdict
e) linear trend-line							—
at the 250 th cycle (K)							—
at the 500 th cycle (K)							—
The value given by each trend-line at the 500 th cycle does not exceed the value given on the trend-line at the 250 th cycle by more than 10 K (ΔK)							
supplementary information: (*) according to new Tables 16; 17; 18							

D.19.5.2				TABLE: temperature rise test for fixed socket-outlets incorporating pilot-lights (*)			N/A
Rated current of accessory (A)							—
AWG size per new Table 16							—
Type of conductors (rigid solid / rigid stranded / flexible) ...							—
Nominal diameter of thread (mm); torque 2/3 of that specified in 12.2.8 (Nm).....							—
specimen	pilot light supplied at rated voltage	fixed socket-outlet loaded at rated current.	external surface of the fixed socket-outlets				allowed ΔT (K)
			metallic material		non-metallic material		
supplementary information: (*) according to new Tables 16; 18							

D.20		TABLE: breaking capacity (*)						N/A	
Rating of accessory (A/V)								—	
Type of accessory (portable / fixed)								—	
AWG size per new Table 16								—	
type of conductors (rigid solid / rigid stranded / flexible)								—	
nominal diameter of thread (mm); torque 2/3 of that specified in 12.2.8 (Nm).....								—	
rate of operation (strokes per minute)								—	
specimen	test plug (for each type and current rating of socket-outlet)		test voltage (1,1 Vn) (V)	test current (1,25 In) cos ϕ 0,6 (A)	number of strokes (plugs only)	number of strokes, with shutters – with current ⁽¹⁾	number of strokes, without shutters – with current ⁽²⁾	remarks	Verdict
	pin dimensions (mm)	pin spacing (mm)							

IEC 60884-1 - Annex D (normative) - TABLES									
Clause	Requirement + Test					Result - Remark			Verdict
supplementary information: (*) according to new Tables 16; 18									
(1) starting point 1 or 3 of Figure 24									
(2) starting point 2 of Figure 24									

D.21	TABLE: normal operation (*)								N/A
	Rating of accessory (A/V)								—
	Type of accessory (portable / fixed)								—
	AWG size per new Table 16								—
	type of conductors (rigid solid / rigid stranded / flexible)								—
	nominal diameter of thread (mm); torque 2/3 of that specified in 12.2.8 (Nm)								—
	rate of operation (strokes per minute)								—
specimen	test plug (for each type and current rating of socket-outlet)		test voltage (V _n) (V)	test current (Table 18), cos φ 0,8 (A)	number of strokes (plugs only)	number of strokes, with shutters – with current ⁽¹⁾	number of strokes, without shutters – with current ⁽²⁾	number of strokes, with shutters – without current ⁽³⁾	Verdict
	pin dimensions (mm)	pin spacing (mm)							
	TABLE: test for shuttered socket-outlets								
specimen	Gauge of Figure 7, applied with a force of 20 N, for approximately 5 s, successively in three directions				Steel gauge of Figure 8, applied with a force of 1 N for approximately 5 s, in three directions				Verdict
19	TABLE: temperature rise test								
specimen	test circuit (L-L / L-N / L-E)	test current (Table 18 for clause 21) for 60+5/0 (A)			measured dT (K)	allowed dT (K)	Verdict		

IEC 60884-1 - Annex D (normative) - TABLES					
Clause	Requirement + Test			Result - Remark	Verdict
17.3	TABLE: electric strength				
specimen	item per 17.2.1 17.2.2 17.2.3	test voltage applied between:	test voltage (V)	flashover / breakdown (Yes/No)	
supplementary information: (*) according to new Tables 16; 18 (1) starting point 1 or 3 of Figure 24 (2) starting point 2 of Figure 24 (3) starting point 1 or 2 of Figure 24					

D.23.2	TABLE: pull and torque test (*)					N/A
	Rated current (A) / rated voltage (V)..... : A / V					—
	Type of accessory (non-rewirable / rewirable) :					—
	Smallest / largest cross-sectional area AWG size per new Table 20 (rewirable accessories) :					—
	Nominal diameter of thread (mm); torque 2/3 per Table 7 (Nm) (rewirable accessories) :					—
specimen	type of flexible cable	number of conductors and nominal cross-sectional area AWG size	pull (100 times) (N) for 1 s without jerks	torque (1 min) as specified in Table 21 (Nm)	displacement (mm)	Verdict
supplementary information: (*) according to new Tables 20; 21						

D.23.4	TABLE: flexing test (*)				N/A
	rated voltage (V) : ... V				—
specimen	type of flexible cable	number of conductors and nominal cross-sectional area AWG size	test current (A)	mass (N)	Verdict
			15	20	
			15	20	
			15	20	
supplementary information: (*) according to new Table 20					

IEC 60884-1 - Annex D (normative) - TABLES							
Clause	Requirement + Test	Result - Remark					Verdict
D.27.1	TABLE: creepage distances, clearances and distances through sealing compound						N/A
	rated voltage (V)						—
item per Table 26	creepage distance dcr, clearance cl and distance through sealing compound dtsc at/of:	required cl (mm)	cl (mm)	required dcr (mm)	dcr (mm)	required dtsc (mm)	dtsc (mm)
		≥		≥		≥	
		≥		≥		≥	
		≥		≥		≥	
		≥		≥		≥	
		≥		≥		≥	
		≥		≥		≥	
supplementary information:							

IEC 60884-1 - Annex E (informative *)
Tests to be applied during the production of crimped connections in accessories

* NOTE In the following countries, Annex E is normative: DE, DK.

E.1	General	N/A
	The production of crimped connections in accessories comply with the following tests	—
	Minimum to be checked during the production and documented: – the crimp height – the pull out force – the micro-section of the crimped connection	N/A
	The limit values of the crimp height and the pull out force are defined by the manufacturer and are given in the test report. These limit values are the reference values for the test during the production	N/A
	As the type tests have been done on samples that fall within the tolerances as defined by the manufacturer, the manufacturer shall have performed a risk analysis when setting the tolerances, and shall detail how the limits on crimp height and pull out force have been established	N/A
E.2	Stripping of the conductor	N/A
	When stripping the conductors, the requirements of 9.4 of IEC 60352-2:2006 have been taken into account.	N/A
E.3	Crimp height	N/A
	The crimp height during production shall remain between the limit lines as given by the manufacturer in the test report. The test is carried out according to IEC 60352-2:2006, 12.2.	N/A
E.4	Pull out force	N/A
	The test is carried out according to IEC 60512-16-4:2008. The values which have been validated during the production shall be between the limit lines as given by the manufacturer in the test report.	N/A
E.5	Microscopic analysis of the prepared crimped connection	N/A
	The micro-section of the crimped connection is the basis for the validation of the quality of the crimp connection obtained with the crimp tool. The micro-section shall be carried out during the type test, in case of tool replacement and modifications	

IEC 60884-1 - Annex E (informative *)			
Clause	Requirement + Test	Result - Remark	Verdict
	The micro-section and the evaluation shall be documented and kept for at least 10 years		N/A
E.6	Process quality		N/A
	The quality of the complete crimping process shall be tested on all crimped terminations of at least 50 specimens by confirming the crimp height as well as the pull out force		N/A
	The test results shall remain between the limit lines as given by the manufacturer in the test report.		N/A
E.7	Production validation		N/A
	During the running manufacturing process the crimp height as well as the pull out force according to the manufacturer's declaration shall be tested according to a statistical process control method		N/A
	Three specimens of each type shall be tested at the beginning and end of a production lot, however at least every 8 h or after 5 000 samples whichever is reached first		N/A
	For lots smaller than 1 000 samples the test has to be performed only at the beginning		N/A
	The test results shall remain between the limit lines as given by the manufacturer in the test report		N/A
	The test results shall be documented by the manufacturer and kept for at least 10 years		N/A

IEC 60884-1 - Annex F (normative)
Additional requirements for accessories provide with insulation-piercing terminals

NOTE The following modifications are applicable for accessories provided with insulation-piercing terminals. The clause numbers in this annex refer to the clause numbers in the main body text of this document.

1	SCOPE	N/A
	<i>Replacement of the second paragraph</i>	—
	Rated current limited to 16 A maximum for accessories provided with screwless-type terminals or with insulation-piercing terminals	N/A
3	TERMS AND DEFINITIONS	N/A
	<i>Addition of new terms</i>	—
3.47	insulation-piercing terminals IPT	N/A
3.47.1	reusable insulation-piercing terminals reusable IPT	N/A
3.47.2	non-reusable insulation-piercing terminals non-reusable IPT	N/A
7	CLASSIFICATION	N/A
7.1	Accessories classification	—
	Addition:	—
7.1.7	IPT classification according to the method of making the connection	N/A
7.1.7.1	with a general purpose tool;	N/A
7.1.7.2	with a special tool, only allowed for non-reusable IPT;	N/A
7.1.7.3	by hand.	N/A
7.1.8	IPT classification according to reusability	N/A
7.1.8.1	Reusable IPT;	N/A
7.1.8.2	Non-reusable IPT.	N/A
	Accessories provided with non-reusable IPT only used in trunking systems in accordance with IEC 61084.	N/A

IEC 60884-1 - Annex F (normative)			
Clause	Requirement + Test	Result - Remark	Verdict
8	MARKING		N/A
8.1	General:		N/A
	<i>Add</i>		N/A
	Accessories with IPT marked with: - length of the conductor to be inserted into the IPT - an indication of the suitability to accept rigid (solid and stranded) conductors only		N/A
8.2	Symbols		N/A
	<i>Add</i>		N/A
	For IPT terminals: suitability to accept rigid conductors only : r		N/A
8.3	Particular requirements for fixed socket-outlets		N/A
	<i>Add</i>		N/A
	- length of the conductor to be inserted into the IPT		N/A
	- indication of the suitability to accept rigid (solid and stranded) conductors only for IPT, for these socket-outlets having this restriction		N/A
8.4	Particular requirements for portable accessories		N/A
	<i>Replace</i>		N/A
	Plugs and portable socket-outlets, the marking specified in 8.1, other than:		N/A
	– type reference		N/A
	– length of the conductor to be inserted into the IPT		N/A
	easily discernible when the accessory is wired and assembled		N/A
	Plugs and portable socket-outlets for equipment of class II not marked with the symbol for class II construction.		N/A
8.9	Manufacturer's documentation for IPTs		N/A
	Connection and disconnection procedure		N/A
	Method of connection according to 7.1.7		N/A
	Non-reusable IPT: information that the product can only use in cable trunking systems and how the product shall be installed in order to have the possibility to replace it, without impairing the safety of the installation		N/A
	An indication that the accessory is equipped with non-reusable insulation piercing terminals		N/A

IEC 60884-1 - Annex F (normative)			
Clause	Requirement + Test	Result - Remark	Verdict
	Information that the conductor shall not be stripped before connecting it to the terminal, unless the manufacturer has designed the product for this purpose		N/A
12	TERMINALS AND TERMINATIONS		N/A
12.1	General		
	<i>Replace</i>		—
	All tests on terminals, with exception of 12.3.11, 12.3.12 and 12.4.11, carried out after the tests of 16.1		N/A
	Rewirable accessories provided with screw-type terminals or with screwless-type terminals or with IPTs		N/A
	Pre-soldered flexible conductors used: in screw-type terminals the pre-soldered area outside the clamp area		N/A
	Clamping means of terminals: not serve to fix any other components, also if they hold the terminals in place or prevent turning		N/A
	Non-rewirable accessories provided with soldered, welded, crimped, non-reusable insulation piercing terminals or equally effective permanent connections (termination)		N/A
	Screw connections and snap-on connections not used		N/A
	IPT requiring a special tool in accordance with classification 7.1.7.2, can only be used for non-reusable IPT		N/A
	Accessories provided with non-reusable IPT: only used in trunking systems in accordance with IEC 61084		N/A
	Non-reusable IPT used in non-rewirable accessories only		N/A
	Pre-soldered crimping connections of a flexible conductor: only if the soldered area is outside the crimping area		N/A
12.4	Insulation piercing terminals (IPT)		—
12.4.1	IPTs: type suitable for rigid copper conductors only		N/A
	or of the type suitable for both rigid and flexible conductors		N/A
	IPTs for rewirable portable accessories: type suitable for flexible copper conductors		N/A

IEC 60884-1 - Annex F (normative)			
Clause	Requirement + Test	Result - Remark	Verdict
12.4.2	IPTs provided with clamping units which allow proper connection of rigid or of rigid and flexible copper conductors having nominal cross-sectional areas shown in Table F.1		N/A
	IPTs accept insulated conductors having the maximum outer diameter specified in Table F.1 and in addition if specified by the manufacturer for other insulation types		N/A
	It is possible to connect an unprepared conductor into the IPTs		N/A
	Contact pressure transmitted by metallic parts		N/A
	Compliance checked by inspection, measurement and/or by fitting conductors of the smallest and largest nominal cross-sectional areas of all kind of conductors accepted by the terminal.		N/A
	When applicable with unstripped and stripped conductors.		N/A
12.4.3	Reusable IPTs: if a new conductor is connected and disconnected, no insulating material of the conductor remains inside the terminal impairing their further use		N/A
	Checked by connecting and disconnecting, on a new set of terminals, the same conductor five times (largest cross-section area / smallest cross-section area of all the conductors given in Table F.1, rotating the conductor in such a way that it is not connected twice at the same place		N/A
	Insulating material of the conductor remained inside the accessory: it is possible to withdraw it, and the terminal is not damaged as to impair its further use		N/A
12.4.4	Parts of IPTs intended for carrying current are of materials as specified in 26.5		N/A
	Checked by inspection / chemical analysis :		N/A
12.4.5	IPTs: they clamp the conductors with sufficient contact pressure and without damage. The conductor is clamped reliably and between metal surfaces.		N/A
	Checked by inspection / test of 12.4.10		N/A
12.4.6	Disconnection of a conductor from a re-usable IPT: required deliberate action to disconnect it by hand or with a suitable tool		N/A
	It is not possible to confuse the opening for the use of a tool with the opening intended for the connection of the conductor		N/A

IEC 60884-1 - Annex F (normative)			
Clause	Requirement + Test	Result - Remark	Verdict
	Checked by inspection / test of 12.4.10		N/A
12.4.7	IPTs used for the interconnection of two or more conductors are designed that:		N/A
	– the clamping of one of the conductors is independent of the clamping of the other conductor(s)		N/A
	– during the connection or for re-usable IPT disconnection, the conductors can be connected or disconnected either at the same time or separately		N/A
	– each conductor is introduced in a separate clamping unit (not necessarily in separate holes)		N/A
	– it is possible to clamp securely any number of conductors up to the maximum as designed		N/A
	Checked by inspection / manual tests		N/A
12.4.8	IPTs: adequate insertion of the conductor is obvious and over-insertion is prevented if further insertion reduces creepage distances / clearances required in Table 26, or influence the operation of the accessory		N/A
	Checked by inspection		N/A
12.4.9	IPTs are properly fixed to the accessory.		N/A
	IPTs do not work loose when the conductors are connected or disconnected during installation		N/A
	Checked by inspection / test of 12.4.10		N/A
	Cover with sealing compound without other clamping means: it is not sufficient		N/A
	Self-hardening resins can be used to fix terminals that are not subjected to mechanical stress in normal use.		N/A
12.4.10	IPTs withstand the mechanical stresses occurring in normal use		N/A
	Re-usable IPTs: tests performed on one terminal of each type of terminal construction of three specimens		N/A
	Terminals suitable for rigid conductors only: checked with rigid solid (Class 1) and rigid stranded (Class 2) conductors in a new set of specimens		N/A
	Terminals suitable for rigid and flexible conductors: checked with rigid solid (Class 1) conductors and on a new set of specimens with flexible (Class 5) conductors		N/A

IEC 60884-1 - Annex F (normative)			
Clause	Requirement + Test	Result - Remark	Verdict
	IPTs suitable for flexible conductors only (rewirable portable accessories): checked with flexible conductors		N/A
	Non-reusable IPTs for rigid conductors: test performed on 6 specimens of each type of terminal. - 3 with the smallest conductor cross-sectional area - 3 with the largest conductor cross-sectional area	See appended Table F.12.4.10	N/A
	Non-reusable IPTs for flexible conductors: - 3 with the smallest conductor cross-sectional area - 3 with the largest conductor cross-sectional area	See appended Table F.12.4.10	N/A
	Terminals also designed to connect stripped conductors: tests repeated on a new set of specimens with stripped conductors		N/A
	Terminal placed in the test apparatus according to Figure 13		N/A
	Terminal fitted first with: a) the maximum number of conductors of the largest nominal cross-sectional area of the same type according to Table F.1	See appended Table F.12.4.10	N/A
	Test repeated with: b) the maximum number of conductors of the smallest nominal cross-sectional area of the same type according to Table F.1	See appended Table F.12.4.10	N/A
	If the terminal is fitted with more than 1 conductor, the test is done on each of the conductors consecutively		N/A
	Length of the test conductor 75 mm longer than the height H specified in Table 10		N/A
	Test conductor connected in the clamping unit in the intended manner		N/A
	The end of the conductor passed through an appropriately sized bushing in a platen positioned at a height H below the equipment as given in Table 10.		N/A
	Bushing positioned in a horizontal plane; its central line described a circle of 75 mm in diameter, concentric with the centre of the locking unit in the horizontal plane, the plane rotated at a speed of (10±2) revolutions per minute		N/A
	Distance between the mouth of the locking unit and the upper surface of the bushing: within 15 mm of the height indicated in Table 10.		N/A

IEC 60884-1 - Annex F (normative)			
Clause	Requirement + Test	Result - Remark	Verdict
	Lubricated bushing to prevent bonding, twisting or rotation of insulated conductor		N/A
	Each conductor introduced in the IPT: rotated for 150 revolutions at a speed of (10 ± 2) revolutions per minute.		N/A
	Used apparatus shown in Figure 13.		N/A
	Conductor subjected to a pull (value Table 10)		N/A
	During the test the conductors do not move noticeably in the clamping unit		N/A
	After each rotation test, the pulling force given in Table 5 applied to the conductor under test.		N/A
	Force applied in one smooth and continuous application, for 1 min, in the direction of the axis of the conductor		N/A
	During the test, the rigid solid (Class 1) conductor, the wire of rigid stranded (Class 2), the flexible (Class 5) conductor neither slipped out of the clamping unit, nor broken near the clamping unit	<input type="checkbox"/> rigid solid conductor <input type="checkbox"/> wire of rigid stranded <input type="checkbox"/> flexible conductor	N/A
	After these tests, neither the terminals nor the clamping devices have become loose and the conductors do not show any deterioration affecting their further use		N/A
	Case of the Class 5 conductor: the breakage of a few wires has not been considered, as no more than 15 % of the original number of wires has been subject to such breakage		N/A
	No lack of the insulating material of the conductor has been observed		N/A
12.4.11	IPTs withstand the electrical and thermal stresses occurring in normal use		N/A
	Test carried out on 12 new IPTs which have not been used for any other test (6 new IPTs for rewirable portable accessories)	See appended Table F.12.4.11	—
	Terminals suitable for rigid conductors only: controlled with solid rigid conductors (class 1) and rigid strands (class 2)		N/A
	Terminals suitable for rigid and flexible conductors: checked with rigid solid (Class 1) conductors and with flexible (Class 5) conductors		N/A
	IPTs suitable for flexible conductors only (rewirable portable accessories): checked with flexible conductors		N/A

IEC 60884-1 - Annex F (normative)			
Clause	Requirement + Test	Result - Remark	Verdict
	Terminals also designed to connect stripped conductors: repeated tests on a new sample set		N/A
	Test made with new copper conductors having the minimum and maximum cross-sectional areas according to Table F.1		N/A
	Before the test, on reusable IPs, a rigid solid conductor with the largest cross section area was connected and disconnected once		N/A
	Conductors with the smallest cross-sectional area were connected to each of the 3 IPs and conductors with the largest cross-sectional area were connected to each of the other 3 IPs		N/A
	Conductors connected to terminals of length 1 m, to ensure normal cooling of the terminals		N/A
	The whole test arrangement, including the conductors, was placed in a heating cabinet, initially maintained at a temperature of $(20 \pm 2) ^\circ\text{C}$ (Figure F.3)		N/A
	The test current defined in Table F.2 has been applied as shown in Figure F.3		N/A
	Used for the tests:	<input type="checkbox"/> AC source <input type="checkbox"/> DC source	—
	The IPTs were then subjected to 192 temperature cycles, each lasting 1 h		N/A
	Air temperature in the cabinet raised to $40 ^\circ\text{C}$ within 20 min		N/A
	It has been maintained within $\pm 5 ^\circ\text{C}$ of this value for 10 min		N/A
	The IPTs have been allowed to cool down in 20 min to a temperature of $30 ^\circ\text{C}$		N/A
	Measurement of the voltage drop: 1) the IPTs were kept at this temperature for 10 minutes. If necessary 2) the IPTs allowed to cool down further at a temperature of $(20 \pm 2) ^\circ\text{C}$	<input type="checkbox"/> 1 <input type="checkbox"/> 2	N/A
	The temperature in the heating chamber was measured at a distance of 50 mm from the samples		N/A
	During this test, the voltage drop measurement was performed at $20 ^\circ\text{C}$ to ensure stability		N/A

IEC 60884-1 - Annex F (normative)			
Clause	Requirement + Test	Result - Remark	Verdict
	Measuring points: 1) were close to the IPT locking unit 2) the measured value was reduced by the value of the voltage drop in the conductor between the two measuring points, as it was not possible	<input type="checkbox"/> 1 <input type="checkbox"/> 2	N/A
	The voltage drop in the IPs has been measured after completion of the 24 th and 192 nd cycles and recorded	See appended Table F.12.4.11	—
	The maximum voltage-drop of each clamping unit, measured with the current specified in Table F.2, do not exceed the smallest of the following two values: - either 22,5 mV or - 1,5 times the value measured after the 24 th cycle	<input type="checkbox"/> 22,5 mV <input type="checkbox"/> mV	N/A
	After the test, no cracks or deformations have occurred which have impaired further use		N/A
12.4.12	Non-reusable IPTs: constructed that it is not possible to disconnect the product without destroying it or by cutting the conductors		N/A
	Checked by inspection		N/A
12.4.13	IPT with screws for wire connection: the following test has been performed before each test of 12.4		N/A
	Screws of IPTs tightened and loosened 5 times applying the torque as stated in the corresponding column of Table 7. A new conductor end has been used each time the screw has been loosened and re-tightened Nm	N/A
	Higher values of torque used (Nm) : Nm	N/A
	During the test the IPT has been not damage		N/A
12.4.14	Screws for making contact-pressure do not serve to fix any other component		N/A
	Screws are not of metal which is soft or liable to creep, such as zinc		N/A
	Used aluminium alloy screws / aluminium alloy bodied IPTs: additional tests in accordance with IEC 61545		N/A
	Checked by inspection		N/A

IEC 60884-1 - Annex F (normative) - TABLES					
Clause	Requirement + Test		Result - Remark	Verdict	
F.12.4.10	TABLE: test with apparatus shown in Figure 13			N/A	
	rated current (A)	:		—	
	type of conductors	:	<input type="checkbox"/> rigid solid <input type="checkbox"/> rigid stranded <input type="checkbox"/> flexible	—	
	smallest/largest cross-sectional area (Table F.1) ...	:		—	
	number of conductors	:		—	
	nom. diameter of thread (mm); torque Table 7 (Nm) :			—	
	Cross-sectional area (mm²)	Diameter of bushing hole per Table 10 (mm)	Height H per Table 10 (mm)	Mass (kg) per Table 10	Verdict
	TABLE: pull test			N/A	
	Cross-sectional area (mm²)	Number of conductors	Type of conductors (rigid solid / rigid stranded / flexible)	Pull per Table 5 applied for 1 min (N)	Verdict
supplementary information:					

IEC 60884-1 - Annex F (normative) - TABLES								
Clause	Requirement + Test			Result - Remark			Verdict	
F.12.4.11	TABLE: voltage drop measurement						N/A	
	IPTs suitable for rigid conductors only			<input type="checkbox"/> rigid solid (Class 1) <input type="checkbox"/> rigid stranded (Class 2)			—	
	IPTs suitable for rigid and flexible conductors			<input type="checkbox"/> rigid solid (Class 1) <input type="checkbox"/> flexible (Class 5)			—	
	IPTs suitable for flexible conductors only			<input type="checkbox"/> flexible (Class 5)			—	
	IPTs suitable for stripped conductors			<input type="checkbox"/> stripped conductor			—	
	Test current Table F.2 (A) A			—	
	Current source			<input type="checkbox"/> AC source <input type="checkbox"/> DC source			—	
	Number of cycles			192			—	
	Duration of each cycle			1 h			—	
	Maximum allowable voltage drop (mV)			- either 22,5 mV or - 1,5 times the value measured after the 24 th cycle			—	
Type of conductor		Minimum			Maximum			Verdict
Cross-sectional area (Table F.1)		... mm ²			... mm ²			—
IPT terminal number		1	2	3	1	2	3	—
Voltage drop 24 th (mV)								
Voltage drop 192 nd (mV)								
Supplementary information:								

IEC 60884-1 - Annex G (informative *)			
Additional tests and requirements for accessories intended to be used in ambient temperatures below $-5\text{ }^{\circ}\text{C}$ down to and including $-45\text{ }^{\circ}\text{C}$			
Clause	Requirement + Test	Result - Remark	Verdict
G.1	Overview		N/A
*	This annex is <u>normative</u> for accessories intended to be used in temperatures below normal range: CA, FI, NO, SE		N/A
	As given in the scope, plugs and socket-outlets complying with the main part of this document are suitable for use at ambient temperatures not normally exceeding $+40\text{ }^{\circ}\text{C}$, but their average over a period of 24 h does not exceed $+35\text{ }^{\circ}\text{C}$, with a lower limit of the ambient air temperature of $-5\text{ }^{\circ}\text{C}$		N/A N/A
	This Annex G provides tests and requirements for accessories used in ambient temperatures below $-5\text{ }^{\circ}\text{C}$ down to and including $-45\text{ }^{\circ}\text{C}$		N/A
	If an accessory is declared for use in this range of temperatures, the declared ambient temperature is $-25\text{ }^{\circ}\text{C}$ or lower		N/A
G.2	General requirements on tests		N/A
	Socket-outlets and plugs are tested using plugs and socket-outlets of the same system (same rated current / number of poles)		N/A
	The following additional tests are conducted on three new specimens previously submitted to the test of 16.1		N/A
	All tests are carried out at a temperature of $-25\text{ }^{\circ}\text{C}$.		N/A
	Lower value: multiple of $5\text{ }^{\circ}\text{C}$		N/A
	All tests are carried out at the declared temperature		N/A
G.3	Marking		N/A
	– Symbol intended for use in cold environment, IEC 60417-6292 (2015-11)		N/A
G.4	Construction of accessories		N/A
G.4.1	Fixing of covers, cover plates		—
	Removal of covers and cover plates: still adequate under the declared cold temperature		N/A
	Accessories are kept for 2 h at the declared cold temperature $\pm 2\text{ }^{\circ}\text{C}$		N/A

IEC 60884-1 - Annex G (informative *)			
Clause	Requirement + Test	Result - Remark	Verdict
	Afterwards, within 1 min, the test is initiated. Forces are gradually applied in directions perpendicular to the mounting surfaces: <ul style="list-style-type: none"> – 40 N, for covers, cover plates, or parts of them complying with the tests of 24.16 and 24.17; or – 80 N, for other covers, cover plates, or parts of them. 		N/A
	The force is applied for 1 min. The covers, cover plates do not come off		N/A
	After the test the specimens do not show damage		N/A
G.4.2	Requirements for membranes in inlet openings		—
	Accessory equipped with membranes: test of 13.23 performed at the declared temperature $\pm 2\text{ }^{\circ}\text{C}$		N/A
G.5	Test for accessories intended to be used in ambient temperatures below $-5\text{ }^{\circ}\text{C}$		N/A
	Switched socket-outlets: each pole of the switch is wired with an electrical indicator, supplied with a voltage 40 V / 50 V to evaluate that it is operating during the test		N/A
	The accessories are kept for 16 h / 24 h at the declared temperature $\pm 2\text{ }^{\circ}\text{C}$		N/A
	Once an hour during the last 4 h, the accessories are subjected to the following test sequence:		—
	1) taken out from the freezer		N/A
	2) afterwards (within 30 s), the following tests are initiated, and the specified operations performed without a break: <ul style="list-style-type: none"> – socket-outlets are tested with a plug of the same rated current at room temperature, which is fully inserted and withdrawn three times; the socket-outlet lid, if any, is opened and closed each time; – plugs are fully inserted and withdrawn three times into a socket-outlet of the same rated current at room temperature; – switched socket-outlets; the switches are operated for 20 operations, before the plug insertion and withdrawal sequence. The rate of operation is 30 operations per minute; each test sequence: 40 s in duration; 		N/A
	3) immediately after the operation described in 2), the accessories are put again into the freezer.		N/A
	During and after this test the accessories operate properly; do not show damage		N/A

IEC 60884-1 - Annex G (informative *)			
Clause	Requirement + Test	Result - Remark	Verdict
G.6	Mechanical strength		N/A
	Products declared as suitable for use at a temperature below $-5\text{ }^{\circ}\text{C}$ meet the mechanical properties required		N/A
	Test for fixed accessories:		N/A
	Flush-type accessories are mounted in a recess provided in a block of hornbeam or material having similar mechanical characteristics, which is fixed to a sheet of plywood, and not in its relevant mounting box.		N/A
	Wood block: direction of the fibres perpendicular to the direction of impact.		N/A
	Flush-type screw fixing socket-outlets: fixed by means of screws. Flush-type claw fixing socket-outlets: fixed by means of the claws.		N/A
	Surface type accessories: mounted on a rigid support by their mounting means		N/A
	Fixing screws main parts / covers: torque two-thirds of that specified in Table 7.		N/A
	The assemblies are kept for 16 h / 24 h at the declared temperature $\pm 2\text{ }^{\circ}\text{C}$		N/A
	The assembly is fixed on a rigid support		N/A
	Test: application of blows by means of spring hammer test equipment (IEC 60068-2-75 Ehb test)		N/A
	Impact energy is applied according to Table G.1		N/A
	The specimens are subjected to evenly distributed blows. The blows are not applied to knock-outs.		N/A
	– for parts specified in A, five blows: <ul style="list-style-type: none"> • one blow to the centre, • one blow on each of the two most unfavourable points between the centre and the edges, horizontally, • one blow on each of the two most unfavourable points between the centre and the edges, vertically; 		N/A
	– for parts specified in B, C, D, four blows: <ul style="list-style-type: none"> • one blow is applied on each side of the specimen where the blow can be applied. 		N/A
	Lines of blows: equidistant from inlet openings.		N/A

IEC 60884-1 - Annex G (informative *)			
Clause	Requirement + Test	Result - Remark	Verdict
	Cover-plates of multiple socket-outlets: treated as corresponding number of separate covers; only one blow is applied to any one point.		N/A
	Socket-outlets with IP code higher than IPX0: lids, if any, closed; in addition, blows are applied to the parts exposed with the lids open.		N/A
	After the test, no damage		N/A
	Lens of pilot light: if cracked / dislodged, it is not possible to touch live parts		N/A
	It is possible to remove and replace external parts		N/A
	A broken cover-plate backed by an inner cover: test repeated on the inner cover		N/A
	Cracks not visible are ignored		N/A
	Cracks or holes in the outer surface are ignored if the accessory complies with this document even with this part omitted.		N/A
	Decorative cover backed by an inner cover: fracture is ignored if it withstands the test after its removal		N/A
	Portable accessories are tested according to 24.5 at the declared temperature		N/A

IEC 60884-1 - Annex H (informative)			
Additional tests and requirements for accessories intended to be used in ambient temperatures above +40 °C up to and including +70 °C			
Clause	Requirement + Test	Result - Remark	Verdict
H.1	Overview		N/A
	As given in the scope, plugs and socket-outlets complying with the main part of this document are suitable for use at ambient temperatures not normally exceeding +40 °C, but their average over a period of 24 h does not exceed +35 °C, with a lower limit of the ambient air temperature of -5 °C.		N/A
	This Annex H provides a methodology for de-rating the operating current of an accessory when used in ambient temperatures above +40 °C up to and including +70 °C.		N/A
H.2	General requirements on tests		N/A
	Socket-outlets and plugs shall be tested using plugs and socket-outlets of the same system, having the same rated current and the same number of poles.		N/A
	The following additional tests shall be conducted on 3 new specimens.		N/A
H.3	Marking		N/A
	It is recommended that accessories in compliance with the requirements of Annex H are marked with a value t_a as determined in H.5.2 if the value of t_a is +40 °C or higher.		N/A
	The marked t_a value are in increments of 5 °C and rounded down to the lower value.		N/A
	For products declared as suitable for use at an ambient temperature above +40 °C, instructions supplying information about the temperature t_a and/or the de-rated current at given ambient temperatures are available in the manufacturer's instructions.		N/A
	Depending on the application, appropriate current limiting devices may be needed to protect the circuit and in this case the information are available in the manufacturer's instructions.		N/A
	Markings are checked by inspection and by the test of 8.8.		N/A
H.4	Construction of accessories		N/A
	If the accessory is equipped with membranes (grommets), the test of 13.22 are performed at (+70 ± 2) °C.		N/A
H.5	Determination of t_a and the rated and de-rated current in relation to the ambient temperature		N/A

IEC 60884-1 - Annex H (informative)			
Clause	Requirement + Test	Result - Remark	Verdict
H.5.1	General		N/A
	Each accessory is wired and installed according to Clause 19 and placed in a heating cabinet.		N/A
H.5.2	Determination of the maximum ambient temperature (t_a) for operation of the accessory at the rated current		N/A
	The value of t_a is determined as follows:		N/A
	Each accessory is loaded at rated current and the temperature in the heating cabinet is adjusted until the highest value of the temperature measured of any terminal is maintained at $(+70 \pm 2)^\circ\text{C}$ for a period of 30 min.		N/A
	The adjusted value of the heating cabinet required to maintain the highest measured temperature of the terminals at $(+70 \pm 2)^\circ\text{C}$ for 30 min is defined as t_a .		N/A
H.5.3	Determination of the de-rated operating currents for ambient temperatures above t_a		N/A
	The temperature of the heating cabinet is then increased by steps of maximum 5°C , the test current being reduced in order to keep the highest measured temperature at the terminals constant at $(70 \pm 2)^\circ\text{C}$.		N/A
	For each step, the measured de-rated operating current (I_d) is recorded.		N/A
	This procedure is continued until the highest measured temperature at the terminals and the heating cabinet is maintained at $(70 \pm 2)^\circ\text{C}$ for a period of 30 min (Figure H.1).		N/A
	De-rating current value at elevated temperature of a product can be given by graph shown in Figure H.1 or at fixed values in increments of 5 K.		N/A
H.6	Test to evaluate the long-term behaviour of the accessories in ambient temperatures above $+40^\circ\text{C}$ up to and including $+70^\circ\text{C}$		N/A
	The tests are conducted in a heating cabinet as described in 16.1 under the following conditions:		N/A
	For switched socket-outlets, before starting the test below, each pole of the switch is wired with an electrical indicator supplied with a voltage between 40 V and 50 V to easily evaluate that it is operating as intended during the test.		N/A
	The specimens are placed in a heating cabinet for seven days at 100°C . For socket-outlets, the test is carried out without a plug inserted.		N/A

IEC 60884-1 - Annex H (informative)			
Clause	Requirement + Test	Result - Remark	Verdict
	The specimens are then taken out of the cabinet and kept at room temperature in a relative humidity between 45 % and 55 % for at least four days (96 h).		N/A
	The specimens do not show no crack visible with normal or corrected vision without additional magnification.		N/A
	The material have not become sticky or greasy, this being judged as follows:		N/A
	– with the forefinger wrapped in a dry piece of rough cloth the specimen is pressed with a force of 5 N;		N/A
	– no traces of the cloth remain on the specimen and the material of the specimen do not stick to the cloth.		N/A
	Then a plug with the same rated current as the socket-outlet is fully inserted and withdrawn 3 times, the socket-outlet lid is opened and closed each time.		N/A
	In the case of switched socket-outlets the switches of the socket-outlets shall be operated for 20 operations before the plug insertion and withdrawal sequence. Rate of operation are 30 operations per minute.		N/A
	During and after this test the switched socket-outlets operates properly.		N/A
	After the test, the specimens do not show damage		N/A
	The tests of 10.5, 22.2, 22.3, 23.2, 23.4, 24.2 and 24.9 of the main body text of this document are performed in addition as applicable.		N/A

Annex I (normative)

Additional requirements and tests for plugs and socket-outlets for high-load (HL) application

NOTE 1 The following modifications are applicable for plugs and socket-outlets for HL application. The clause numbers in this annex refer to the clause numbers in the main body text of this document.

It is desirable that high-load (HL) equipment should only operate in the HL mode when it is connected via a HL plug to a HL socket-outlet. When the HL equipment is connected to a non-HL socket-outlet it should operate in the normal load mode.

The verification of this requirement is not covered by this document. In order to verify this requirement additional measures and/or requirements may apply at national level.

NOTE 2 Measures to prevent HL operation, when using a non-HL socket-outlet, can consist of reducing the current flow by means of recognition systems, thermal monitoring, power limiting devices or other techniques.

Functional safety requirements can be covered by the relevant IEC International Standards.

NOTE 3 In the following countries, an HL solution is not allowed: AT, DE, NO

NOTE 4 In the following countries, the HL concept for plugs and socket-outlets is not applicable: CA, SE, US

Additional measures and/or requirements may apply at national level.

IEC 60884-1 - Annex I (normative)			
Clause	Requirement + Test	Result - Remark	Verdict
8	MARKING		N/A
8.1	Addition:		—
	- for socket-outlets, the symbol for HL, adding the cross-sectional area of the conductor that has to be connected to the socket-outlet to ensure the HL suitability. This value is the cross-sectional area which is submitted to the test of 19.7.3		N/A
	- for non-rewirable plugs, the symbol for HL		N/A
	- for rewirable plugs, the symbol for HL adding the cross-sectional area of the conductor that has to be connected to the plug to ensure the HL suitability. This value is the highest cross-sectional area which is submitted to the test of 19.6.3		N/A
8.2	Addition:		—
	Symbol of suitability for HL		N/A
	Cross section of the conductor to be used with the HL accessories (□ or mm ²)		N/A
	Symbol HL placed next to the rated current of the socket-outlet		N/A
8.3	Addition:		—
	Symbol for HL		N/A
	Additional marking on the outside of the enclosure indicating suitability for HL		N/A
8.7	Addition:		—
	Socket-outlets for HL: the cross-sectional area of the conductors used is stated in the manufacturer's literature		N/A
	Provided manufacturer's instructions for the correct installation and wiring of HL socket-outlets		N/A
9	CHECKING OF DIMENSIONS		N/A
9.2	Addition:		—
	When a HL plug can be connected to a normal load socket-outlet the connected equipment shall operate according to national requirements.		N/A
12	TERMINALS AND TERMINATIONS		N/A
12.2	Terminals with screw clamping for external copper conductors		—
12.2.1	<i>Replacement:</i>		—
12.2.1	HL accessories are provided with terminals which allow the connection of copper conductors having nominal cross-sectional areas shown in Table 4		N/A

IEC 60884-1 - Annex I (normative)			
Clause	Requirement + Test	Result - Remark	Verdict
	<i>Addition of rows to Table 4:</i>		—
	Current and type of accessory (A) (HL plugs) :	... A (HL plugs)	N/A
	Flexible copper conductors	—	—
	Nominal cross-sectional area (mm ²):	... mm ²	—
	Diameter of the largest conductor (mm) :	... mm	—
13	CONSTRUCTION OF FIXED SOCKET-OUTLETS		N/A
	<i>Addition:</i>		—
13.24	Interchangeability of covers or cover plates for design A for HL socket-outlets		—
	Cover or cover-plate containing measures to enable HL operation cannot be placed on non-HL socket-outlets		N/A
14	CONSTRUCTION OF PLUGS AND PORTABLE SOCKET-OUTLETS		N/A
14.26	Replacement		—
14.26	Portable socket-outlets are not suitable for HL		—
	<i>Addition:</i>		—
14.27	Plugs for HL		—
	Plugs for HLs comply with additional requirements		N/A
	- Live pins of plugs are of solid metal construction or a folded-over metal blade construction		N/A
	- For rewirable plugs: <ul style="list-style-type: none"> terminals of rewirable plugs shall have a minimum rated connecting capacity as given in Table 4 the cable anchorage of rewirable plugs is suitable for a cable type IEC 60245 IEC 66 of the appropriate cross-sectional area 		N/A
	- For non-rewirable plugs: <ul style="list-style-type: none"> non-rewirable plugs is supplied with cables having at least the cross-sectional areas as given in Table 4 		N/A
	Checked by inspection and by connection of the relevant conductors and cables		N/A
14.28	Plugs for HL with temperature sensors		—
	Plugs for HL with temperature sensors comply with 14.21 and in addition:		N/A
	- Temperature sensors are able to monitor the temperature according to 14.21		N/A

IEC 60884-1 - Annex I (normative)			
Clause	Requirement + Test	Result - Remark	Verdict
	- The temperature sensors are selected according to the expected accuracy and foreseeable temperature range for the measurement and are placed in the relevant location in the plug for a proper measurement		N/A
	Checked by inspection		N/A
19	TEMPERATURE RISE		N/A
19.1	General		—
	<i>Addition:</i>		—
	Socket-outlets for HL are tested according to 19.2 and 19.7.		N/A
	Plugs for HL are tested according to 19.2 and 19.6.		N/A
	<i>Replacement of Table 16</i>		—
19.2	Test for plugs and socket-outlets		—
	<i>Addition:</i>		—
	- HL plugs and socket-outlets: AC or DC as specified in Table 18 is passed, for sufficient time to reach the steady-state value, or 4 hours, whichever is shorter	See appended Table I.19.2	N/A
	<i>Addition:</i>		—
19.6	Plugs for HL applications		—
19.6.1	General		—
	Plugs for HL withstand without harmful effect: - mechanical - electrical - thermal stresses occurring when connected to HL equipment		N/A
	Tested three new specimens		N/A
	Plugs are tested in accordance with 19.6.2 and 19.6.3 in a draught-free environment		N/A
19.6.2	Test setup		—
	Plug live pins inserted in clamping units having dimensions of Figure 19, with: <ul style="list-style-type: none"> • 2,5 mm² flexible conductors for rated currents up to and including 16 A • 6 mm² for rated currents over 16 A at least 1 m long.		N/A

IEC 60884-1 - Annex I (normative)			
Clause	Requirement + Test	Result - Remark	Verdict
	Screw of the clamping unit is placed in the middle of the bare part of the pin and tightened with a torque of 0,8 Nm		N/A
	Each clamping unit is equipped with a thermocouple		N/A
	Clamping unit modified in order to perform the test (diameter of the screw, threaded hole, total volume identical to Figure 19)		N/A
	Rewirable plug fitted with a cable; cross-sectional area given for HL in Table 16, type IEC 60245 IEC66		N/A
	Terminal screws or nuts tightened; torque as given in Table 7		N/A
	Length of the cable from the cable anchorage is $(1,5 \pm 0,05)$ m		N/A
	Non-rewirable plugs are tested as delivered by the manufacturer		N/A
	Plug fixed on a vertical wooden sheet; 20 mm thick		N/A
	Weight of the full length of the cable transmitted to the cord anchorage		N/A
	Pins maintained in horizontal position		N/A
19.6.3	Test procedure and acceptance criteria		—
	Each cycle: an overload test current as given in Table I.1 according to the nominal cross-sectional area of the conductors connected is passed for 5 h (0 + 10 min) through the live pins (no through the earthing circuit). Afterwards the plug left without current for 1 h (0, - 5 min)	See appended Table I.19.6.3	N/A
	Table I.1 – Test current for cycling tests on plugs		—
	Cable cross sectional area mm ²		N/A
	Rated current of the plug		N/A
	Test current (A)		N/A
	Number of cycles: 125	See appended Table I.19.6.3	N/A
	Each cycle: temperature rise measured within the last 5 min before the end of the current-carrying period		N/A
	Compliance of the plug:		—
	a) no more than one temperature rise measurement of each connection exceed 45 K	See appended Table I.19.6.3	N/A

IEC 60884-1 - Annex I (normative)			
Clause	Requirement + Test	Result - Remark	Verdict
	b) the average of the six temperature rise measurements of the clamping units recorded at the 125 th cycle do not exceed 35 K	See appended Table I.19.6.3	N/A
	The measurement of the temperature rise of any connection exceeded 30 K; additional compliance condition fulfilled:		N/A
	c) a linear trend-line of all six temperature rise measurements has been calculated and drawn through the measurement points from the 50 th to the 125 th cycle. The value given by each trend-line at the 125 th cycle do not exceed the value given on the trend-line at the 50 th cycle by more than 5 K	See appended Table I.19.6.3	N/A
	The linear trend-line is calculated as in 19.5.1.2		N/A
19.7	Socket-outlets for HL applications		—
19.7.1	General		—
	HL socket-outlets withstand without harmful effects: - mechanical - electrical - thermal stresses occurring when supplying HL equipment		N/A
	Tested three new specimens		N/A
	HL socket-outlets are tested in accordance with 19.7.2 and 19.7.3 in a draught-free environment.		N/A
19.7.2	Test setup		—
	Flush-mounted socket-outlets are mounted in flush-mounted boxes as defined in Clause 19		N/A
	They are fitted with rigid PVC insulating conductors according to Table 16 or with the cable specified by the manufacturer for HL, 1 m in length		N/A
	Surface-type socket-outlets are mounted on the surface of a wooden sheet, 20 mm thick		N/A
	Surface-type socket-outlets are fitted with cables according to Table 16 or with the cable specified by the manufacturer for HL, length 1 m.		N/A
	The cable(s) connected to the socket-outlet enter through the top of the box. the point(s) of entry sealed to prevent the circulation of air		N/A
	Length of conductors within the box: (80 ± 10) mm		N/A
	Torque value of terminal screws or nuts: specified in 12.2.8		N/A
	Each specimen is mounted on a vertical surface with the plane through the contacts of the socket-outlets horizontal		N/A

IEC 60884-1 - Annex I (normative)			
Clause	Requirement + Test	Result - Remark	Verdict
	The test plug is a HL plug or a gauge having the same current rating as the socket-outlet and complying with the following criteria:		N/A
	Compliance of the gauge: <ul style="list-style-type: none"> - the linear trend line of the measurements on each pin of these plugs, when tested according to the tests for HL plugs, show a maximum increase of 5 K, taken from the 50th to the 125th cycle, and the maximum individual temperature rise of the individual measurements is not higher than 30 K 		N/A
	The plug is fitted with a (1,5 ± 0,05) m cable measured from the cord anchorage having a cross-sectional area according to Table 17, type 60227 IEC 53.		N/A
	The plug is inserted and withdrawn without the current being passed by means of a test apparatus		N/A
19.7.3	Test procedure and acceptance criteria		—
	Each cycle: the rated current is passed for five hours (0, + 5 min) between the live contacts. The plug is then removed for 1 h (0, - 5 min)		N/A
	Number of cycles: 125	See appended Table I.19.7.3	N/A
	Each cycle: temperature rise at the terminals measured within the last 5 min before the end of the current-carrying period		N/A
	Compliance of the HL socket-outlet:		N/A
	a) no more than one temperature rise measurement of each connection exceed 45 K	See appended Table I.19.7.3	N/A
	b) the average of the six temperature rise measurements of the terminals recorded at the 125 th cycle do not exceed 35 K	See appended Table I.19.7.3	N/A
	The measurement of the temperature rise of any connection exceeded 30 K; additional compliance condition fulfilled:		—
	c) a linear trend-line of all six temperature rise measurements has been be calculated and drawn through the measurement points from the 50 th to the 125 th cycle. The value given by each trend-line at the 125 th cycle do not exceed the value given on the trend-line at the 50 th cycle by more than 5 K	See appended Table I.19.7.3	N/A
	The linear trend line is calculated as in 19.6.3		N/A

IEC 60884-1 - Annex I (normative) - TABLES							
Clause	Requirement + Test			Result - Remark			Verdict
I.19.2	TABLE: temperature rise test for plugs and socket-outlets for HL						N/A
	rated current of accessory (A)			13 / 16 / 20 / 25 / 32 A			—
	type of accessory (portable / fixed)						—
	portable accessory (non-rewirable / rewirable)						—
	nominal cross-sectional area per Table 16 (mm ²) mm ²			—
	type of conductors (rigid solid / rigid stranded / flexible)						—
	nominal diameter of thread (mm); torque 2/3 of that specified in 12.2.8 (Nm) mm; ... Nm			—
specimen	type of flexible cable ⁽¹⁾	number of conductors and nominal cross-sectional area (mm ²) ⁽¹⁾	test circuit (L-L/L-N/L-E)	test current (A) (Table 18) for time to reach the steady-state value, or 4 hours (h)	measured ΔT (K)	allowed ΔT (K)	ΔT of external parts of insulating material (25.3)(K)
				... A / ... h			
				... A / ... h			
				... A / ... h			
supplementary information: ⁽¹⁾ Non-rewirable accessories							

IEC 60884-1 - Annex I (normative) - TABLES							
Clause	Requirement + Test	Result - Remark				Verdict	
I.19.6.3	TABLE: temperature rise test for plugs for HL applications						N/A
	rated current of plug					—	
	overload test current (Table I.1) (A)					—	
	portable accessory (non-rewirable / rewirable)					—	
	nominal cross-sectional area (mm ²)					—	
Specimens (*)	A		B		C		Verdict
Clamping units number (*)	1	2	3	4	5	6	
measurement at the 50 th cycle (K)							—
measurement at the 75 th cycle (K)							—
measurement at the 100 th cycle (K)							—
measurement at the 125 th cycle (K)							—
a) no more than one temperature rise measurement of each connection exceed 45 K							
b) temperature rise measurement average at the 125 th cycle (max 35 K)							
c) linear trend-line							—
at the 50 th cycle (K)							—
at the 125 th cycle (K)							—
The value given by each trend-line at the 125 th cycle do not exceed the value given on the trend-line at the 50 th cycle by more than 5 K (ΔK)							
(*) NOTE 1 the six temperature rises correspond to the temperature rise values of the clamping units of the three specimens							

IEC 60884-1 - Annex I (normative) - TABLES							
Clause	Requirement + Test			Result - Remark			Verdict
I.19.7.3	TABLE: temperature rise test socket-outlets for HL applications						N/A
	rated current of socket-outlet (A)						—
	type of accessory (flush-mounted / surface-type) ...						—
	nominal cross-sectional area (mm ²)						—
	nominal diameter of thread (mm); torque value as specified in 12.2.8 (Nm)						—
Specimens (*)	A		B		C		Verdict
Clamping units number (*)	1	2	3	4	5	6	
measurement at the 50 th cycle (K)							—
measurement at the 75 th cycle (K)							—
measurement at the 100 th cycle (K)							—
measurement at the 125 th cycle (K)							—
a) no more than one temperature rise measurement of each connection exceed 45 K							
b) temperature rise measurement average at the 125 th cycle (max 35 K)							
c) linear trend-line							—
at the 50 th cycle (K)							—
at the 125 th cycle (K)							—
The value given by each trend-line at the 125 th cycle do not exceed the value given on the trend-line at the 50 th cycle by more than 5 K (ΔK)							
(*) NOTE the six temperature rises correspond to the temperature rise values of the clamping units of the three specimens							

Attachment No.1 (Dimensions)

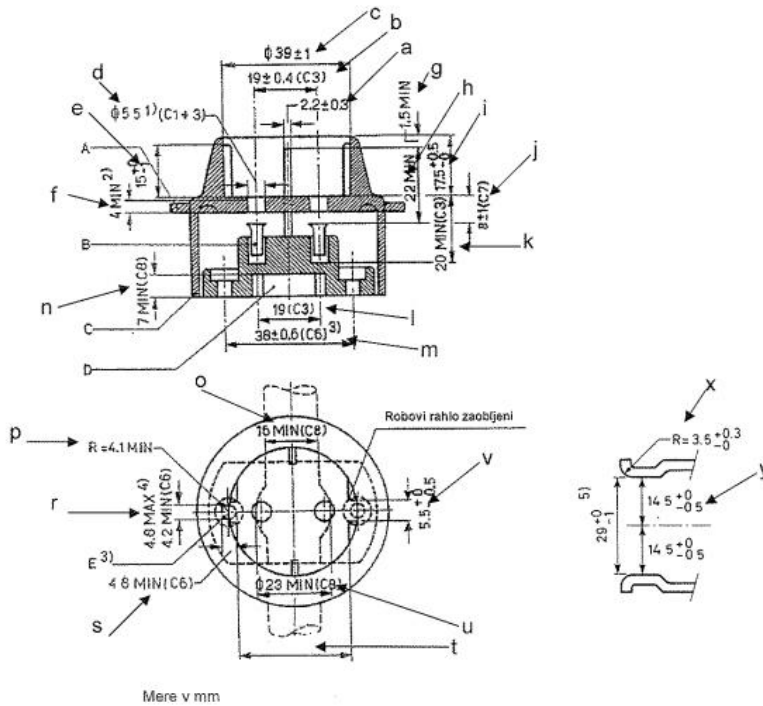

REFERENCE	MEASURED (mm)	REQUIRED (mm)	VERDICT
a	2,3	1.9 – 2.5	P
b	19,0	18.6 – 19.4	P
c	39,4	$\varnothing 38 - 40$	P
d	5,7	$\varnothing 5.5 – 5.8$	P
e	14,4	14 - 15	P
f	8,1	4 min.	P
g	3,1	1.5 min.	P
h	22,9	22 min.	P
i	17,8	17.5 - 18	P
j	8,1	7 - 9	P
k	20,7	20 min.	P
l	N/A	19	N/A
m	N/A	37.4 – 38.6	N/A
n	N/A	7 min.	N/A
o	N/A	16 min.	N/A
p	N/A	R=4.1 min	N/A
r	N/A	4.2 – 4.8	N/A
s	N/A	4.8 min	N/A
t	33,3	33 – 33.5	P
u	N/A	23 min.	N/A
v	5,3	5 – 5.5	P
x	3,6	R= 3.5 – 3.8	P
y	28,5	28 - 29	P

Attachment No.2 (Photos)



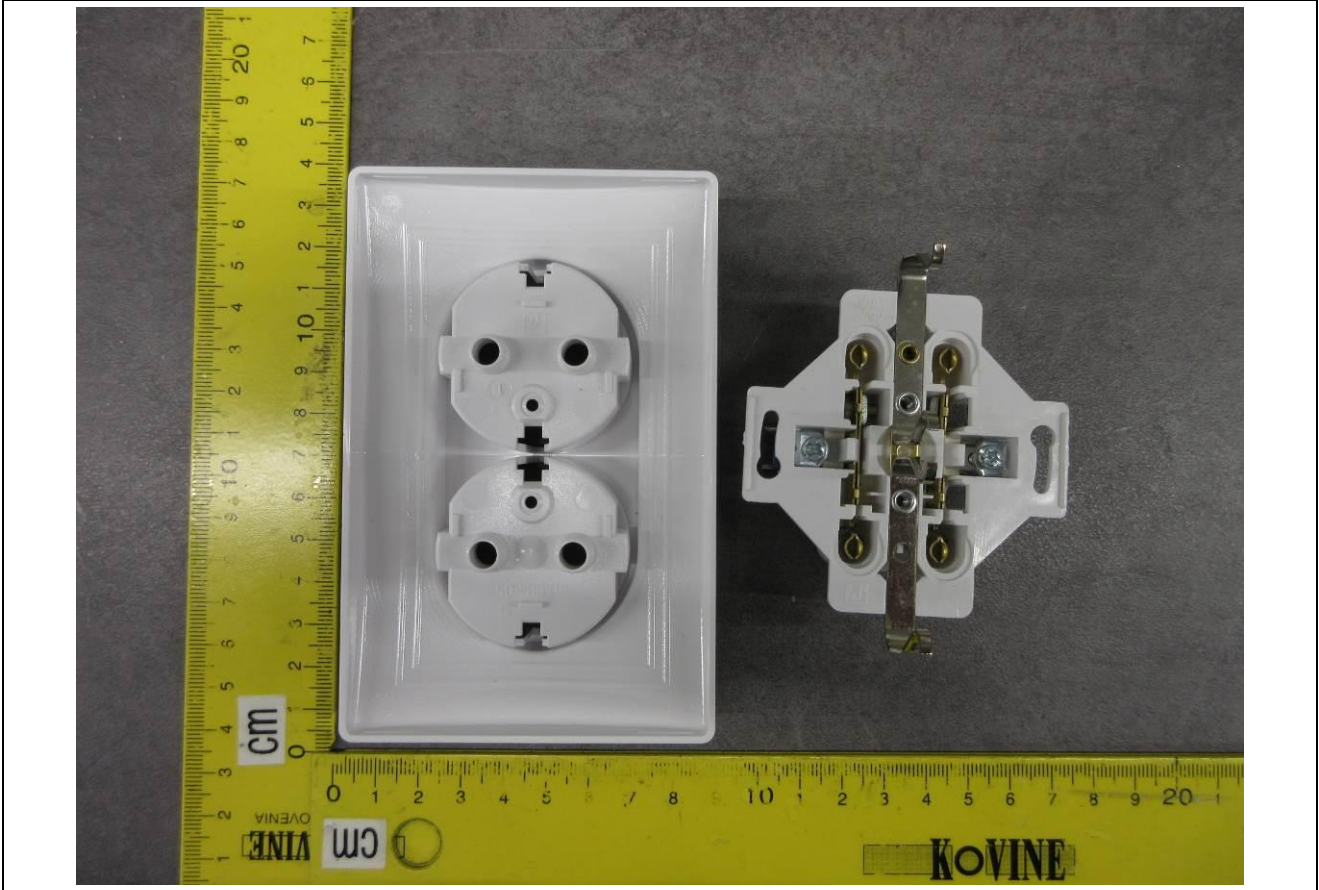

Attachment No.3 (Technical documentation)

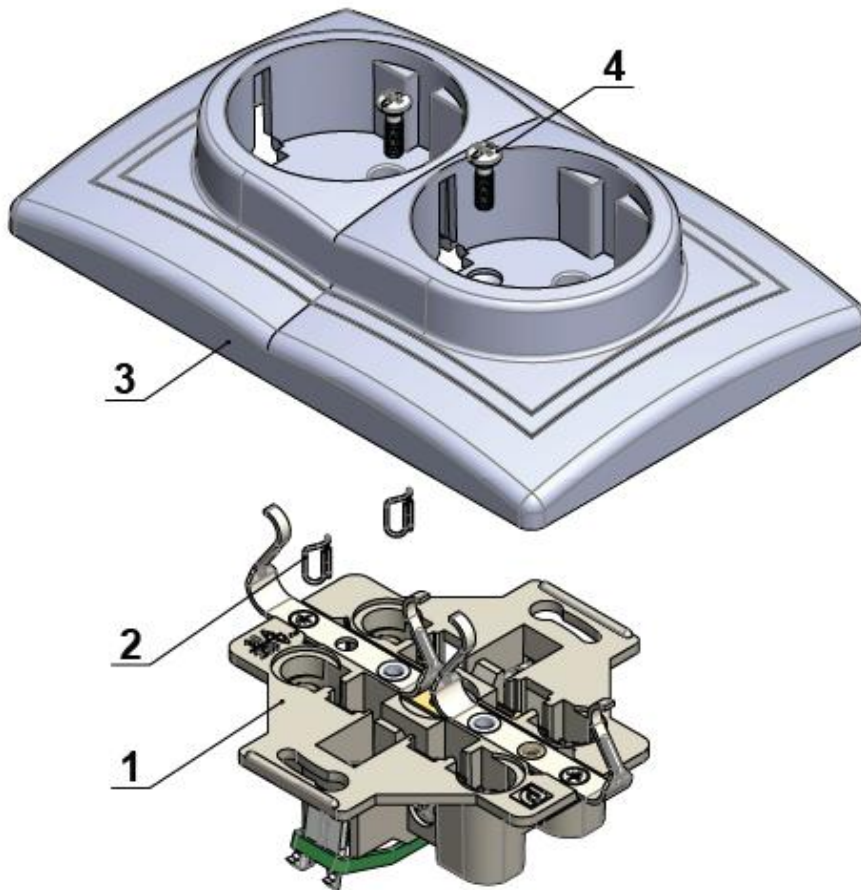

4	Vijak M3x10 ISO 7047 modifikovan	1000142	2	5.8	1000142	gal Zn 5
3	Maska-međuram duple PRESTIGE_PC	art.604.05	1	PC		
2	Opruga kontaktne čaure MODUL 45	art.2311.24	2	1.1200 DIN 2076-C	1000496	brunirano
1	Telo duple priključnice sklop	PSK.5041.1	1			
Poz.	Naziv	Oznaka	Kom.	Materijal	Dim./ Šifra za nabavku	Napomena
	Materijal				Površinska zaštita	Termička obrada
					ID Broj	Masa
					008429	83.567
						Razmera
						1:1
	Sklup	Kom.				
Pripadnost				Naziv		
600-Priključnice_PRESTIGE				PRIKLJUČNICA DVPOLNA PRESTIGE DUPLA SA PLAST. TELOM		
				Oznaka		
				art.604.00		
				Revizija		
				15		
				Tolerancije slobodnih mera		
Datum		Ime				
12.10.17.		Jovica Ristić				
12.10.17.		Jovica Ristić				
30.12.24		Jovica Ristić				
30.12.24		Jovica Ristić				
Konstruisao						
Crtao						
Pregledao						
Odobrio						

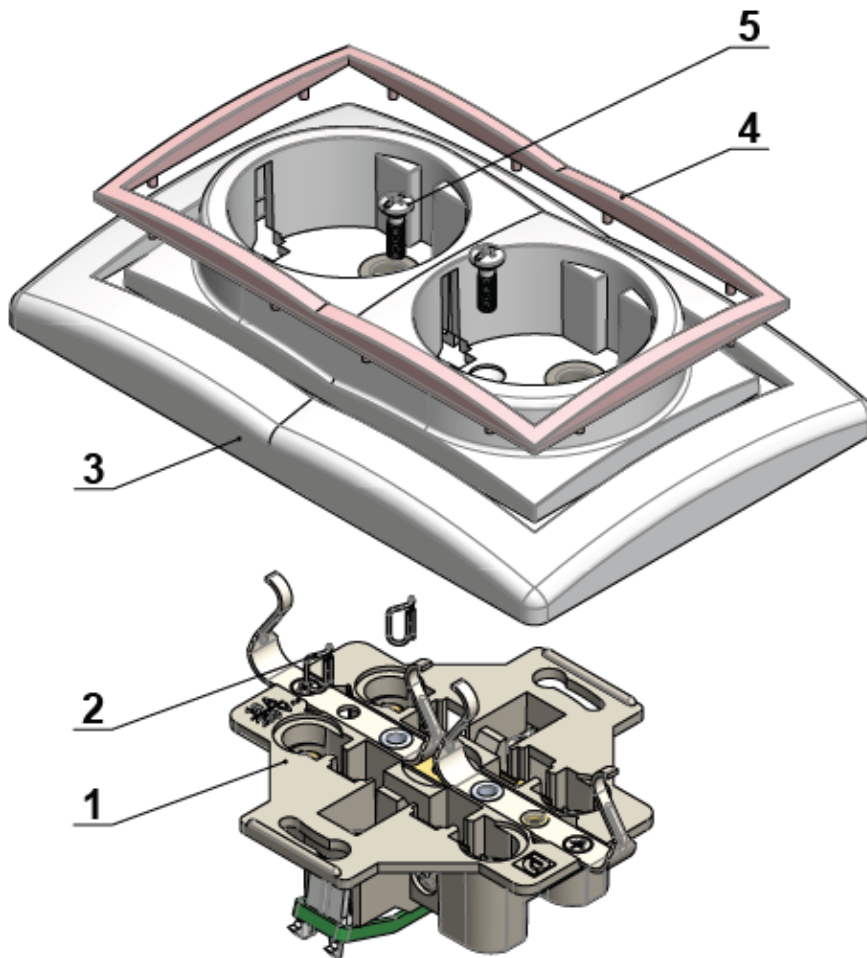

5	Vijak M3x10 ISO 7047 modifikovan	1000142	2	5.8	1000142	gal Zn 5
4	Međuram duple PRESTIGE	art.604.02	1	ABS		
3	Maska duple sklop PRESTIGE	PSK.604.1	1			
2	Opruga kontaktne čaure MODUL 45	art.2311.24	2	1.1200 DIN 2076-C	1000496	brunirano
1	Telo duple priključnice sklop	PSK.5041.1	1			
Poz.	Naziv	Oznaka	Kom.	Materijal	Dim./ Šifra za nabavku	Napomena
	Materijal				Površinska zaštita	Termička obrada
	Dim./Šifra za nabavku				ID Broj	Masa
Sklop	Kom.				008429	86.292
Pripadnost	600-Priključnice_PRESTIGE				Naziv	Razmera
	Tolerancije slobodnih mera				PRIKLJUČNICA DVOPOLNA PRESTIGE DUPLA SA PLAST. TELOM	
Konstruisao	Datum	Ime		ALING-CONEL GAJDOBRA	Oznaka	Revizija
Crtao	12.10.17.	Jovica Ristić			art.604.XX	15
Pregledao	12.10.17.	Jovica Ristić				
Odobrio	30.12.24	Jovica Ristić				